

**City of Roswell  
Purchasing Division**

**Gary Palmer  
City Administrator**

**Jere Wood  
Mayor**

**ADDENDUM NUMBER 1**

**INVITATION TO BID# 17-311-G**

**HOG WALLOW TRAIL PROJECT  
November 29, 2017**

**To All Prospective Bidders:**

**In reference to the ITB listed above, the following changes, clarifications, and answers to questions are hereby incorporated into the Invitation To Bid:**

**Changes:**

Replace the current Plans page entitled "Cross Section" with Typical Sections with Attachment A to this Addendum - Typical Sections.

Delete all references to a grass parking lot and replace with references to a gravel parking lot. Replace the current Price Bid Form with Attachment B to this Addendum.

**Clarifications:**

During the mandatory pre-bid there were some discussions regarding cut/fill estimates for the area located approximately mid project. For bidding purposes, Bidders must make their own estimates regarding the cut/fill requirements for this section of the trail based on the currently staked centerline.

There was also discussion regarding moving the centerline for the trail to the top of the berm that surrounds the open grassy area in the North-Eastern area of the project. Please use the currently staked centerline for bidding purposes.

**Questions and Answers:**

#	QUESTION	ANSWER
1.	On what date will the recommended contractor be approved by the City Council?	As soon as possible following determination of the responsible bidder with the lowest responsive bid - potentially mid-December.

2.	What is the anticipated award date?	See Question 1.
3.	Is the Offeror required to submit a bid bond that will not expire for a 180-day period following bid submission?	Yes.
4.	If my company doesn't have five projects to reference as part of a bid submittal, can I reference completed projects by the company's general contractor? {The general contractor has completed projects as part of a company he owns. The general contractor is also an owner of this company.}	We look for five projects (where company participated as prime contractor) of substantially the same type and scale of work for the company bidding as a prime contractor. This applies to the company that is proposing on the project, not individuals.
5.	Can you clarify with some degree of detail the storm drain crossings. It appears there are three crossings needed at a minimum. Bedding stone? Cover depth?	See Attachments to Addendum #1. Approximate number and location of crossings are provided on the plans in Drawing No. 13-0001.
6.	Your detail shows 8' path with 1' shoulders- yesterday you mentioned the base material is to be 10' wide- drawing contradicts that statement- please clarify.	Trailway is 10' wide – Trailbed is 8' wide, leaving two shoulders of approximately 1 ft. each. Drawing matches.
7.	Can you clarify the extent of the erosion control required? You mentioned the south end of the project only.	Assume silt fence along entire length of project on downstream side of proposed trail.
8.	Can you tell us how much the fee for the LDP will be?	\$0
9.	Can you clarify what type of grass you expect to be planted in the parking area?	The parking lot shall be constructed of 6-in crushed stone with an aggregate size not to exceed ¾-in.
10.	How many linear feet?	Approximately 1,300 feet. This is an approximate measurement – bidders may field verify exact length. Access to the site is open.
11.	Is there any allowance for weather?	The City will consider reasonable requests for time extension due to unseasonable weather and other circumstances beyond the Contractor's reasonable control.
12.	Do any trees need to be removed	No large trees will need to be removed. The Black Oak and Maple trees marked on the plans are not intended for removal.

13.	How will materials testing and compaction be handled? Will there be a changes process if material does not meet compaction with the GAB lifts?	Materials testing and compaction will be monitored by City Staff. If an area needs to be undercut, this will be handled in a change order.
14.	How will the erosion control be handled? How much does the LDP cost, and what requirements are there?	See Answers to Questions 7 and 8.
15.	For Alternate 1, what type of stone should be used?	The trail for Alternate 1 shall be constructed of 6-in crushed stone with an aggregate size not to exceed ¾-in.
16.	Is the fence for the parking lot to be included in the parking lot price?	Yes.
17.	Is there lighting for 24/7 access?	No lighting, full access. Contractors must stay within the working hours described in the bid documents.
18.	Can you provide more detail on how you want us to handle crossings?	We will provide cover details in this addendum #1.
19.	After the pre bid meeting, the project is pretty basic will you allow contractors such as Landscaping contractors and Paving contractors to bid, a GC license should not be mandatory in this project due to the fact that there are no structures being involved?	A GC license or equivalent GDOT certification is required for this contract.
20.	Also the parking area in the proposed bid, do you want sod or seed and straw, or hydro seed ?	See number 9.

All other terms, conditions, and deadlines remain the same.

**COMPLETE THIS ADDENDUM, SIGN and SUBMIT with the ITB to:**

**City of Roswell – Purchasing Division  
Roswell City Hall  
38 Hill Street, Suite 130  
Roswell, GA 30075**

**I hereby acknowledge receipt of Addendum 1 and have incorporated the changes into my proposal response for the above mentioned ITB.**

**COMPANY NAME:** \_\_\_\_\_ **CONTACT PERSON:** \_\_\_\_\_

**ADDRESS:** \_\_\_\_\_ **CITY:** \_\_\_\_\_ **STATE:** \_\_\_\_\_ **ZIP:** \_\_\_\_\_

**PHONE:** \_\_\_\_\_ **FAX:** \_\_\_\_\_ **EMAIL ADDRESS:** \_\_\_\_\_

**SIGNATURE:** \_\_\_\_\_ **DATE:** \_\_\_\_\_

Attachment A to Addendum #1  
ITB#17-311-G

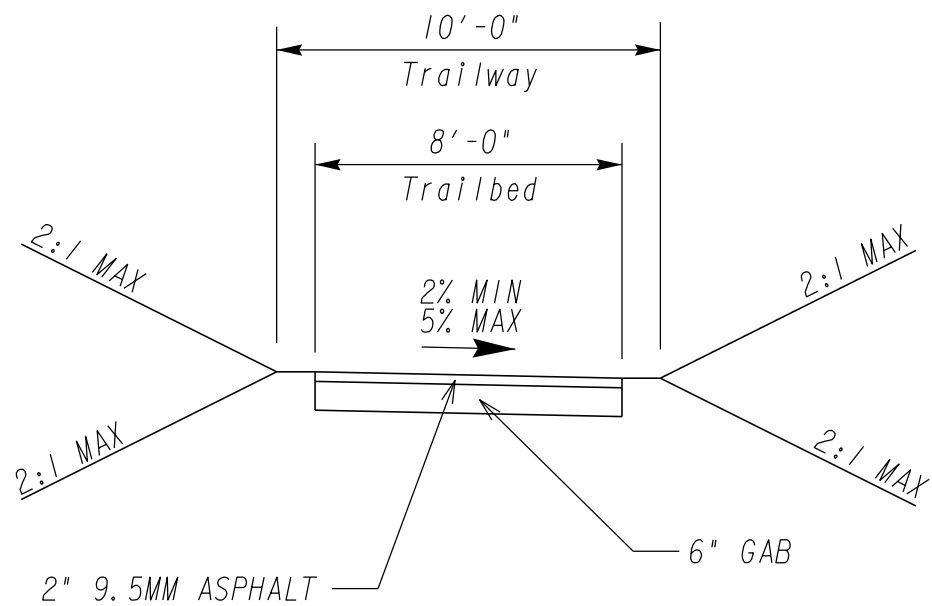

BASE BID  
HARD SURFACE TRAIL

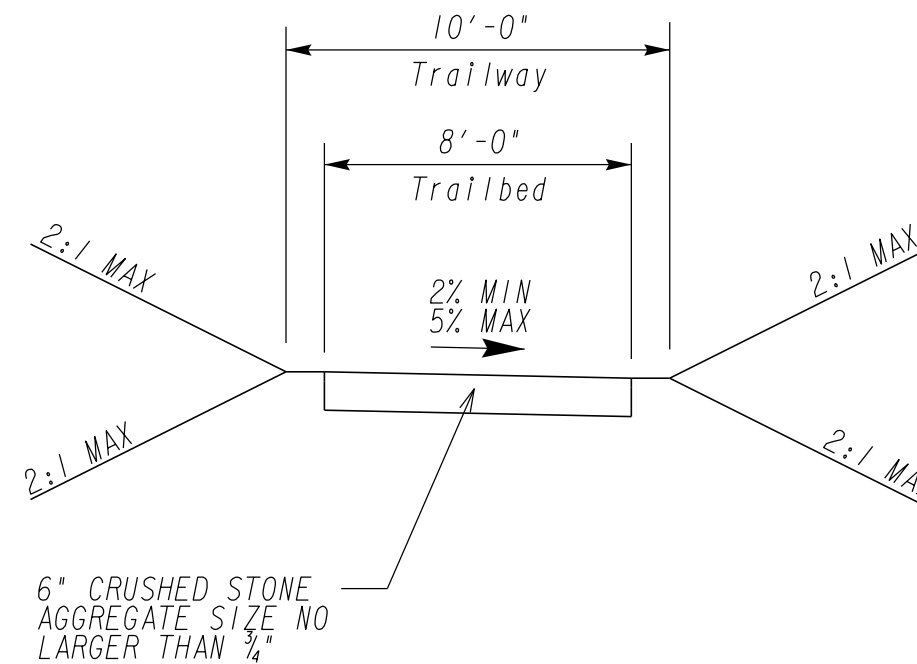

ALTERNATE # 1  
SOFT SURFACE TRAIL

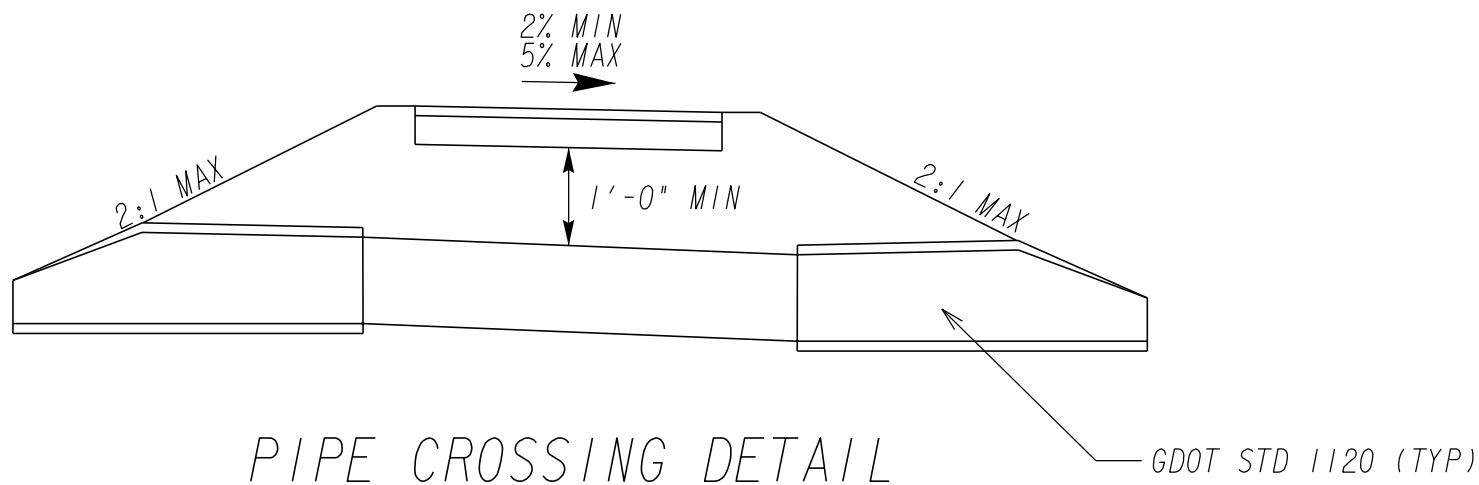

PIPE CROSSING DETAIL



N. T. S.

REVISION DATES

NO.	DATE	DESCRIPTION

TYPICAL SECTIONS

CHECKED:	DATE:	DRAWING No.
BACKCHECKED:	DATE:	05-0001
CORRECTED:	DATE:	
VERIFIED:	DATE:	

**PRICE BID FORM - ATTACHMENT A**

Bid Summary

ITB# 17-311-G

Hog Wallow Trail Project

ITEM	DESCRIPTION	LUMP SUM BID TOTAL
1 <sup>1</sup>	Hard Surface Trail – Asphalt (Base Bid)	\$
Alt. 1	Soft Surface Trail – Crushed Gravel	\$
Alt. 2	Gravel Parking Lot (See Appendix C, Bid Alternate #2)	\$
Alt. 3	Landscaping (See Section 3.2)	\$

---

<sup>1</sup> This same amount is to be reflected in words and numbers on the Bid Form.