



**INVITATION TO BID 16-259-L**

**FOR**

**ROSWELL AREA PARK PHYSICAL ACTIVITY CENTER BUILDING B  
EXTERIOR RENOVATIONS**

BIDS DUE: No later than Thursday, September 15, 2016, 2:00 PM EST in hard copy. Electronic submissions via e-mail or fax will NOT be accepted.

Questions should be directed in writing to City of Roswell Purchasing Division,  
via e-mail to:

[purchasing@roswellgov.com](mailto:purchasing@roswellgov.com)

**Submit Proposals to:  
City of Roswell  
Purchasing Division  
38 Hill Street, Suite 130  
Roswell, Georgia 30075**

## Contents

---

<b>CONTENTS .....</b>	<b>2</b>
<b>BID LETTER AND CERTIFICATION .....</b>	<b>4</b>
<b>OFFEROR'S ITB CHECKLIST.....</b>	<b>5</b>
<b>SCHEDULE OF EVENTS .....</b>	<b>6</b>
<b>PROJECT OVERVIEW.....</b>	<b>7</b>
<b>SECTION 1: ITB INSTRUCTIONS.....</b>	<b>8</b>
1.1 SINGLE POINT OF CONTACT.....	8
1.2 REQUIRED REVIEW .....	8
1.2.1REVIEW ITB.....	8
1.2.2ADDENDA.....	8
1.2.3FORM OF QUESTIONS: .....	8
1.2.4THE CITY OF ROSWELL'S ANSWERS .....	8
1.3 PRE-BID CONFERENCE.....	9
1.4 SUBMITTING A SEALED BID .....	9
1.4.1ORGANIZATION OF BID:.....	9
1.4.2FAILURE TO COMPLY WITH INSTRUCTIONS:.....	9
1.4.3MULTIPLE BIDS:.....	10
1.4.4COPIES REQUIRED AND DEADLINE FOR RECEIPT OF SEALED BIDS:.....	10
1.4.5 <i>Late Submissions, Withdrawals, and Corrections</i> .....	10
1.5 OFFEROR'S CERTIFICATION.....	10
1.5.1UNDERSTANDING OF SPECIFICATIONS AND REQUIREMENTS: .....	10
1.5.2OFFEROR'S SIGNATURE: .....	10
1.5.3OFFER IN EFFECT FOR 120 DAYS: .....	11
1.6 COST OF PREPARING A BID.....	11
1.6.1ROSWELL NOT RESPONSIBLE FOR PREPARATION COSTS: .....	11
1.6.2ALL TIMELY SUBMITTED MATERIALS BECOME ROSWELL'S PROPERTY: .....	11
<b>SECTION 2: ITB RECEIPT AND EVALUATION PROCESS.....</b>	<b>12</b>
2.1. AUTHORITY.....	12
2.2. RECEIPT OF BIDS AND PUBLIC INSPECTION.....	12
2.2.1PUBLIC INFORMATION:.....	12
2.2.2BUYER'S REVIEW OF BIDS: .....	12
2.3. CLASSIFICATION AND EVALUATION OF BIDS .....	12
2.3.1INITIAL CLASSIFICATION OF BIDS AS RESPONSIVE OR NONRESPONSIVE: .....	12
2.3.2DETERMINATION OF RESPONSIBILITY:.....	12
2.3.3EVALUATION OF BIDS:.....	13
2.3.4COMPLETENESS OF BIDS: .....	13
2.3.5OPPORTUNITY FOR DISCUSSION/NEGOTIATION:.....	13
2.3.6CONTRACT AWARD: .....	13
2.4. ROSWELL'S RIGHTS RESERVED .....	13
<b>SECTION 3: SCOPE OF PROJECT/SPECIFICATIONS .....</b>	<b>15</b>

3.1 CITY’S INTENT .....	15
3.2 REQUIRED INFORMATION: SCOPE OF WORK .....	15
3.2.1 PERMITTING .....	15
<b>SECTION 4: OFFEROR QUALIFICATIONS .....</b>	<b>16</b>
4.1 CITY’S RIGHT TO INVESTIGATE .....	16
4.2 OFFEROR INFORMATIONAL REQUIREMENTS .....	16
4.2.1 GEORGIA CONTRACTORS LICENSE PREQUALIFICATION: .....	16
4.2.2 REFERENCES:.....	16
<b>SECTION 5: COST SUBMISSION .....</b>	<b>17</b>
<b>SECTION 6: TERMS AND CONDITIONS .....</b>	<b>18</b>
6.1 ADDITIONAL CONTRACT PROVISIONS AND TERMS.....	18
6.2 PERFORMANCE PRIOR TO CONTRACT EXECUTION .....	18
6.3 CONTRACT TERM .....	18
6.4 CONTRACT TERMINATION .....	19
6.5 SUBCONTRACTORS .....	19
6.6 BONDING REQUIREMENTS .....	19
6.7 GENERAL INSURANCE REQUIREMENTS.....	19
6.8 COMPLIANCE WITH WORKERS’ COMPENSATION ACT .....	20
6.9 COMPLIANCE WITH ILLEGAL IMMIGRATION REFORM AND ENFORCEMENT ACT .....	20
E-VERIFY PROGRAM: .....	20
6.10 COMPLIANCE WITH LAWS .....	22
6.11 DRUG-FREE WORKPLACE.....	22
6.11.1 CERTIFICATION:.....	22
6.11.2 PENALTIES.....	22
6.12 SUBSTITUTIONS AND CHANGE ORDERS.....	23
6.13 INVOICING AND PAYMENT.....	23
6.14 TAXES .....	24
6.15 DELIVERIES .....	24
<b>APPENDIX A – STANDARD FORMS .....</b>	<b>25</b>
<b>BID BOND .....</b>	<b>28</b>
<b>REFERENCES.....</b>	<b>30</b>
<b>LIST OF SUBCONTRACTORS .....</b>	<b>33</b>
<b>CORPORATE CERTIFICATE.....</b>	<b>34</b>
<b>AFFIDAVIT VERIFYING CONTRACTOR PARTICIPATION IN FEDERAL WORK AUTHORIZATION PROGRAM .....</b>	<b>35</b>
<b>CONTRACT AGREEMENT .....</b>	<b>36</b>

## BID LETTER AND CERTIFICATION

---

**(FAILURE TO INCLUDE THIS SIGNED BID LETTER AND BID CERTIFICATION MAY RESULT IN THE REJECTION OF YOUR BID.)**

We propose to furnish and deliver any and all of the deliverables and services named in the attached ITB 16-259-L Roswell Area Park Physical Activity Center Building B Exterior Renovations for the City of Roswell for which prices have been set. The price or prices offered herein shall apply for the period of time stated in the ITB.

It is understood and agreed that this proposal constitutes an offer, which when accepted in writing by Purchasing Division, City of Roswell, and subject to the terms and conditions of such acceptance, will constitute a valid and binding contract between the undersigned and the City of Roswell ("City").

It is understood and agreed that we have read the City's specifications shown or referenced in the ITB and that this proposal is made in accordance with the provisions of such specifications. By our written signature on this proposal, we guarantee and certify that all items included in this proposal meet or exceed any and all such City specifications described in this ITB. We further agree, if awarded a contract, to deliver goods and services which meet or exceed the specifications. The City reserves the right to reject any or all proposals, waive technicalities, and informalities, and to make an award in the best interest of the City.

It is understood and agreed that this proposal shall be valid and held open for a period of one hundred twenty (120) days from proposal opening date.

### PROPOSAL SIGNATURE AND CERTIFICATION

I certify that this proposal is made without prior understanding, agreement, or connection with any corporation, firm, or person submitting a proposal ("Offeror") for the same materials, supplies, equipment, or services and is in all respects fair and without collusion or fraud. I understand collusive bidding is a violation of state and federal law and can result in fines, prison sentences, and civil damage awards. I agree to abide by all conditions of the proposal and certify that I am authorized to sign this proposal for the Offeror. I further certify that the provisions of O.C.G.A. § 45-10-20, et seq. have not been violated and will not be violated in any respect.

Authorized Signature for Offeror \_\_\_\_\_

Date \_\_\_\_\_

Print/Type Name \_\_\_\_\_

Print/Type Offeror Name Here \_\_\_\_\_

Phone: \_\_\_\_\_ Email Address: \_\_\_\_\_

## OFFEROR'S ITB CHECKLIST

---

### 10 Critical Things to Keep in Mind When Responding to an ITB for the City of Roswell

1. \_\_\_\_\_ **Read the *entire* document.** Note critical items such as: supplies/services required; submittal dates; number of copies required for submittal; contract requirements (e.g. bonding and insurance requirements); etc.
2. \_\_\_\_\_ **Note the Buyer's name, address, phone numbers and e-mail address.** This is the **only** person you are allowed to communicate with regarding the ITB and is an excellent source of information.
3. \_\_\_\_\_ **Attend the pre-bid conference** if one is offered. These conferences provide an opportunity to ask clarifying questions, obtain a better understanding of the project, or to notify the City of any ambiguities, inconsistencies, or errors in the ITB. This conference may be mandatory.
4. \_\_\_\_\_ **Take advantage of the “question and answer” period.** Submit your questions to the Buyer by the due date listed in the *Schedule of Events* and view the answers given in the formal “addenda” issued for the ITB. All addenda issued for an ITB are posted on the City’s website and will include all questions asked and answered concerning the ITB.
5. \_\_\_\_\_ **Follow the format required in the ITB** when preparing your response. Provide point-by-point responses to all sections in a clear and concise manner.
6. \_\_\_\_\_ **Provide complete answers/descriptions.** Read and answer **all** questions and requirements. Don’t assume the City will know what your company’s capabilities are or what items/services you can provide, even if you have previously contracted with the City. The proposals are evaluated based solely on the information and materials provided in your response.
7. \_\_\_\_\_ **Use the forms provided**, e.g. cover page, bid sheet, standard forms, etc.
8. \_\_\_\_\_ **Check the City’s website for ITB addenda.** Before submitting your response, check the City’s website at <http://www.roswellgov.com/bids.aspx> to see whether any addenda were issued for the ITB. **If so, you must submit a signed cover sheet for each addendum issued along with your ITB response.**
9. \_\_\_\_\_ **Review the ITB document again** to make sure that you have addressed all requirements. Your original response and the requested copies must be identical and complete. The copies are provided to the Evaluation Committee members and will be used to score your proposal.
10. \_\_\_\_\_ **Submit your proposal on time.** Note all the dates and times listed in the *Schedule of Events* and within the document, and be sure to submit all required items on time. Late proposal responses will not be accepted.

***This checklist is provided for assistance only and should not be submitted with Offeror’s Bid.***

## SCHEDULE OF EVENTS

---

<u>EVENT</u>	<u>DATE</u>
ITB Issue Date.....	August 15, 2016
Deadline for Receipt of Written Questions.....	August 30, 2016 (2:00PM)
Deadline for Posting of Written Answers to City’s Website.....	September 2, 2016
ITB Response Due Date.....	September 15, 2016 (2:00 PM)
ITB Opening – ITB Participants Declared.....	September 15, 2016 (2:30 PM)
Anticipated Award Date.....	September 2016

*(All time references in this document are to be understood as local, Eastern Time for our City, Roswell, GA.)*

## PROJECT OVERVIEW

---

The City of Roswell Mayor and Council, the governing authority of City of Roswell, Georgia (“the City”), through the Roswell Recreation and Parks Department, requests sealed bids for a project consisting of Exterior Renovations at the Physical Activity Center Building “B” located at Roswell Area Park, located at 10495 Woodstock Road, Roswell, GA 30075.

## SECTION 1: ITB INSTRUCTIONS

---

### 1.1 Single Point of Contact

---

From the date this Invitation to Bid (the "ITB") is issued until an Offeror is selected, **Offerors are not allowed to communicate with any staff (other than designee below) or elected officials of the City regarding this procurement.** Any unauthorized contact may disqualify the Offeror from further consideration. Contact information for the single point of contact is as follows:

Buyer:	Lynn Shriner
Address:	38 Hill Street Roswell, GA 30075
Telephone Number:	770-641-3718
E-mail Address:	<a href="mailto:purchasing@roswellgov.com">purchasing@roswellgov.com</a>

### 1.2 Required Review

---

- 1.2.1 **Review ITB:** Offerors should carefully review this ITB in its entirety including all instructions, requirements, specifications, and terms/conditions and promptly notify the Buyer, identified above, in writing or via e-mail of any ambiguity, inconsistency, unduly restrictive specifications, or error which may be discovered upon examination of this ITB.
- 1.2.2 **Addenda:** The City of Roswell may revise this ITB by issuing an addendum prior to its opening. The addendum will be posted on the City's website alongside the posting of the ITB at <http://www.roswellgov.com>. Addenda will become part of the bid documents and subsequent contract. Offerors must sign and return any addendum with their ITB response. Failure to propose in accordance with an addendum may be cause for rejection. In unusual circumstances, the City of Roswell may postpone an opening in order to notify vendors and to give Offerors sufficient time to respond to the addendum.
- 1.2.3 **Form of Questions:** Offerors with questions or requiring clarification or interpretation of any section within this ITB must address these questions in writing or via e-mail to the Buyer referenced above on or before **August 30, 2016**. Each question must provide clear reference to the section, page, and item in question. Questions received after the deadline may not be considered.
- 1.2.4 **The City of Roswell's Answers:** The City of Roswell will provide by **September 2, 2016**, an official written answer to all questions received within the period stipulated under *section 1.2.3*. The City of Roswell's response will be by formal written addendum. Any other form of interpretation, correction, or change to this ITB will not be binding upon the City of Roswell. Any formal written addendum will be posted on the City's website alongside the posting of the ITB at <http://www.roswellgov.com> by the close of business on the date listed. Offerors must sign and return any addendum with their ITB response.



There will be no pre-bid conference for this project.

1.4 Submitting a Sealed Bid

---

1.4.1 **Organization of Bid:** Each bid shall be prepared simply and economically, providing straight-forward, concise delineation of the Offeror's capabilities to satisfy the requirements of this ITB. To expedite the evaluation of proposals, it is essential that Offerors follow the format and instructions contained herein.

Offeror shall reference the bid number and closing date and time on the **outside, lower left corner** of the envelope containing the bid. Failure to include such information may delay opening of the bid.

Offerors must organize their bids in the following format:

- a. **Bid Letter and Certification** – Offeror's authorized representative(s) shall complete and sign the Bid Letter and Certification on page 4 of this ITB and return it with the bid.
- b. **Scope of Project/Specifications** – Offeror shall respond comprehensively and clearly to the requirements of *Section 3* and shall include all documents, information, exceptions, clarifications, etc., as requested therein.
- c. **Offeror Qualification** – Offeror shall include all requested documents and information.
- d. **Cost Submission** – Offeror's authorized official to complete, sign, and return with bid response.
  - 1. Offerors **must** respond to this ITB by utilizing the Schedule of Items found in Appendix E.
  - 2. Except in rare cases as described in Section 1.4.5, a bid may not be corrected, withdrawn, or canceled by the Offeror for a 120-day period following the deadline for bid submission as defined in the Schedule of Events, or receipt of best and final offer, if required, and Offeror so agrees in submitting the bid.
  - 3. The Cost Bid Form will be used as the primary representation of each Offeror's cost/price, and will be used extensively during bid evaluations.
  - 4. Additional information should be included as necessary to explain in detail the Offeror's cost/price.
- e. **Appendix A, Standard Forms** – Offeror's authorized representative(s) **must** complete the standard forms and return with bid response.
- f. **Appendix B, Contract**
- g. **Addenda** – if any addenda have been issued, complete, sign and return the Bid Cost Form and reference All Addenda issued for bid.

1.4.2 **Failure to Comply with Instructions:** The City of Roswell may also choose not to evaluate, may deem non-responsive, and/or may disqualify from further consideration

any proposals that do not follow this ITB format, are difficult to understand, are difficult to read, or are missing any requested information.

1.4.3 **Multiple Bids:** Offerors may, at their option, submit multiple bids, in which case each bid shall be evaluated as a separate document. Multiple bids must be submitted in separate envelopes and marked plainly to notify that each envelope contains a separate and single bid response.

1.4.4 **Copies Required and Deadline for Receipt of Sealed Bids:** All bids must be received in sealed opaque packaging. Offerors must submit the following number of copies to the address set forth on the Cover Page:

- One (1) unbound hard copy (3-ring binder OK) marked "Original" with original signatures; and
- One (1) electronic copy. The electronic copy shall be submitted in pdf format (OCR) and organized in the same format as the original submission with each Chapter or Section of the original having a corresponding Electronic File.

Bids must be received sealed and at the Purchasing Office of the location noted on the Cover Page prior to **2:00 PM (EST), on September 15, 2016**. Facsimile or e-mail responses to invitation for bids are NOT accepted.

1.4.5 **Late Submissions, Withdrawals, and Corrections:**

- A. **Late Bid:** Regardless of cause, late bids will not be accepted and will automatically be disqualified from further consideration. It shall be the Offeror's sole risk to assure delivery to the Purchasing Office by the designated time. Late bids will not be opened and may be returned to the Offeror at the expense of the Offeror or destroyed if requested.
- B. **Bid Withdrawal:** An Offeror requesting to withdraw its bid prior to the ITB due date and time may submit a letter to the Buyer requesting to withdraw. The letter must be on company letterhead and signed by an individual authorized to legally bind the firm.
- C. **Bid Correction:** If an obvious clerical error is discovered after the bid has been opened; the Offeror may submit a letter to the designated Buyer within two business days of opening, requesting that the error be corrected. The letter must be on company letterhead and signed by an individual authorized to legally bind the firm. The Offeror must present clear and convincing evidence that an unintentional error was made. The Buyer will review the correction request and a judgment will be made. Generally, modifications to opened bids for reasons other than obvious clerical errors are not permitted.

## 1.5 Offeror's Certification

---

1.5.1 **Understanding of Specifications and Requirements:** By submitting a response to this ITB, Offeror agrees to an understanding of and compliance with the specifications and requirements described in this ITB.

1.5.2 **Offeror's Signature:** All signatures required in the bid on behalf of an Offeror must be signed in ink by an individual authorized to legally bind the business submitting the bid. The Offeror's signature on a bid in response to this ITB guarantees that the prices quoted

have been established without collusion and without effort to preclude the City of Roswell from obtaining the best possible supply or service. Proof of authority of the person signing the ITB response must be furnished upon request.

- 1.5.3 **Offer in Effect for 120 Days:** Except in rare cases as described in *Section 1.4.5*, a bid may not be corrected, withdrawn, or canceled by the Offeror for a 120-day period following the deadline for bid submission as defined in the Schedule of Events, or receipt of best and final offer, if required, and Offeror so agrees in submitting the bid.

## 1.6 **Cost of Preparing a Bid**

---

- 1.6.1 **Roswell Not Responsible for Preparation Costs:** The costs for developing and delivering responses to this ITB and any subsequent presentations of the bid as requested by the City of Roswell are entirely the responsibility of the Offeror. The City of Roswell is not liable for any expense incurred by the Offeror in the preparation and presentation of their bid.
- 1.6.2 **All Timely Submitted Materials Become Roswell's Property:** All materials submitted in response to this ITB become the property of the City of Roswell and are to be appended to any formal documentation, which would further define or expand any contractual relationship between the City of Roswell and Offeror resulting from this ITB process.

## SECTION 2: ITB RECEIPT AND EVALUATION PROCESS

---

### 2.1. Authority

---

This ITB is issued under the authority of the City of Roswell.

### 2.2. Receipt of Bids and Public Inspection

---

**2.2.1 Public Information:** During the opening of sealed bids, the Offeror's name, bid amount, and other pertinent information will be read aloud and recorded. No other information will be disclosed at that time. Each bid offer is considered open record and all information received in response to this ITB, including copyrighted material, is deemed public information and will be made available for public viewing and copying shortly after bid opening with the following four (4) exceptions: (1) bona fide trade secrets meeting confidentiality requirements that have been properly marked, separated, and documented; (2) matters involving individual safety as determined by the City of Roswell; (3) any company financial information requested by the City of Roswell to determine vendor responsibility, unless prior written consent has been given by the Offeror; and (4) other constitutional protections.

**2.2.2 Buyer's Review of Bids:** Upon opening the sealed bids received in response to this ITB, the Buyer in charge of the solicitation will review the bids and separate out any information that meets the referenced exceptions in *Section 2.2.1* above, providing the following conditions have been met:

- Confidential information is clearly marked and separated from the rest of the bid;
- Bid does not contain confidential material in the cost/price section; and
- An affidavit from an Offeror's legal counsel attesting to and explaining the validity of the trade secret claim is attached to each bid containing trade secrets.

Information separated out under this process will be available for review only by Buyer, the Finance Director, and limited other designees. Offerors must be prepared to pay all legal costs and fees associated with defending a claim for confidentiality in the event of a "right to know" (open records) request from another party.

### 2.3. Classification and Evaluation of Bids

---

**2.3.1 Initial Classification of Bids as Responsive or Nonresponsive:** All bids will initially be classified as either "responsive" or "nonresponsive". Bids may be found nonresponsive at any time during the evaluation process or negotiations if: any of the required information is not provided; the submitted price is found to be excessive or inadequate as measured by criteria stated in the ITB; or the bid is not within the plans and specifications described and required in the ITB. Bids found nonresponsive may not be considered further.

**2.3.2 Determination of Responsibility:** The Buyer will determine whether an Offeror has met the standards of responsibility. Such a determination may be made at any time during the evaluation process and through negotiation if information surfaces that would result in a determination of non-responsibility. If an Offeror is found non-responsible, the determination must be in writing and made a part of the procurement file.

2.3.3 **Evaluation of Bids:** During the evaluation of the bids, the City reserves the right to request clarification of bid responses and to request the submission of references, if deemed necessary for a complete evaluation of bid responses.

Award will be made to the responsive and responsible Offeror whose bid is most economical according to designated criteria. The determination of the lowest responsive and responsible Offeror may involve all or some of the following factors:

- price,
- conformity to specifications,
- financial ability to meet the contract,
- previous performance,
- facilities and equipment,
- availability of repair parts,
- experience,
- delivery promise,
- terms of payment,
- compatibility as required,
- other cost,
- and other objective and accountable factors, if any.

The City shall be the judge of the factors and will make the award in the best interest of the City.

2.3.4 **Completeness of Bids:** Selection and award will be based on the Offeror's bid and other items outlined in this ITB. Submitted responses may not include references to information located elsewhere, such as Internet websites or libraries, unless specifically requested. Information or materials presented by Offerors outside the formal response or subsequent discussion/negotiation, if requested, will not be considered, will have no bearing on any award, and may result in the Offeror being disqualified from further consideration.

2.3.5 **Opportunity for Discussion/Negotiation:** After receipt of all bids and prior to the determination of the award, the City of Roswell may initiate discussions with one or more Offerors should clarification or negotiation be necessary.

2.3.6 **Contract Award:** Award, if any, will be made by the Mayor and City Council, upon recommendation, to the Offeror providing the lowest responsive and responsible bid and who provides all required documents.

## 2.4. Roswell's Rights Reserved

---

While the City of Roswell has every intention to make an award as a result of this ITB, issuance of the ITB in no way constitutes a commitment by the City of Roswell to award and execute a contract. Upon a determination such actions would be in its best interest, the City of Roswell, in its sole discretion, reserves the right to:

- Cancel or terminate this ITB at any time. A notice of cancellation will be issued on the Roswell website. If the ITB is cancelled, the City of Roswell will not reimburse any Offeror for the preparation of its bid. Bids may be returned upon request if unopened;
- Reject any or all bids received in response to this ITB,
- Make a contract award, based directly on the bids received, determined to be in the best interest of the City, in its sole discretion,
- Enter into further discussions with one or more Offerors;

- Waive and/or amend any undesirable, inconsequential, or inconsistent provisions/specifications of this ITB which would not have significant impact on any bid;
- Not award if it is in the best interest of the City of Roswell; or
- Terminate any contract if the City of Roswell determines adequate funds are not available.

## SECTION 3: SCOPE OF PROJECT/SPECIFICATIONS

---

### 3.1 City's Intent

---

The City of Roswell Mayor and Council, the governing authority of City of Roswell, Georgia ("the City"), through the Roswell Recreation and Parks Department, requests sealed bids for a project consisting of exterior renovations at the Physical Activity Center Building "B" at Roswell Area Park, located at 10495 Woodstock Road, Roswell, GA 30075

### 3.2 Required Information: Scope of Work

---

Offeror shall perform exterior renovations at the Physical Activity Center Building "B" at Roswell Area Park, located at 10495 Woodstock Road, Roswell, GA.

See Attachment - Drawing and Plan Design by DMD Engineering and Testing Inc

#### 3.2.1 Permitting:

At the time of issuance of a Purchase Order for this Work, contractor is responsible for all permits.

#### Responsibilities

- City of Roswell shall provide access to the worksite during normal working hours.
- Contractor shall coordinate staging area for materials and equipment with the City of Roswell as needed.
- City of Roswell shall provide parking area for contractor equipment and vehicles during construction.
- City of Roswell will be responsible for tree and plant material removal.
- City of Roswell must approve color scheme.
- City of Roswell must evaluate and approve any proposed changes to the scope of work.
- Contractor shall coordinate other inspections required for this project

ANY DEVIATION FROM SPECIFICATIONS MUST BE COMPLETELY EXPLAINED BY OFFEROR.

Offeror will explain exact particulars where bid does not meet exactly the specification above, or drawings.

## SECTION 4: OFFEROR QUALIFICATIONS

---

### 4.1 City's Right to Investigate

---

The City may make such investigations as deemed necessary to determine the ability of the offeror to provide the supplies and/or perform the services specified.

### 4.2 Offeror Informational Requirements

---

In determining the capabilities of an offeror to perform the services specified herein, the following informational requirement(s) must be met by the offeror.

4.2.1 **Georgia Contractors License Prequalification:** Offeror shall provide a copy of their current Certificate of Qualification or Certificate of Registration. (If required)

4.2.2 **References:** Offeror shall provide a list of references for the last five (5) clients/projects of the same general size and scope that is proposed in this ITB which the offeror has been awarded. The City reserves the right to use any information or additional references deemed necessary to establish the ability of the offeror to perform the conditions of the contract. Note that the reputation of the Offeror regarding adequacy of their past skillful performance of work of this type and magnitude required herein, shall be considered when making the award of contract and lack thereof is grounds for bid rejection. **(See Appendix A for Reference Form)**



## **SECTION 5: COST SUBMISSION**

---

Offerors shall respond to this bid utilizing the Cost Bid Form on Page 26 of this ITB.

## SECTION 6: TERMS AND CONDITIONS

---

The City of Roswell's Terms and Conditions are set forth below. Offerors should notify the City of Roswell of any Terms and Conditions that either preclude them from responding to the ITB or add unnecessary cost. This notification must be made by the deadline for receipt of written/e-mailed questions or with the Offeror's ITB response. Any requests for material, substantive, important exceptions to the standard terms and conditions will be addressed by formal written addendum issued by the designated Buyer. The City of Roswell reserves the right to address any non-material, minor, insubstantial exceptions to the terms and conditions with the highest-scored Offeror at the time of contract negotiation.

### 6.1 Additional Contract Provisions and Terms

---

This ITB, including all ITB documents and any addenda, the Offeror's bid, including any amendments, any clarification question responses, and any negotiations shall be included as part of the contract upon award. In the event of a dispute as to the duties and responsibilities of the parties under the contract, the contract, along with any attachments prepared by the City of Roswell, will govern in the same order of precedence as listed in the contract.

### 6.2 Performance Prior to Contract Execution

---

The successful Offeror shall not begin performance of the project prior to the execution of a formal written contract by the City of Roswell and the Offeror. Any Offeror beginning performance prior to the execution of the contract shall be deemed to be proceeding at the Offeror's risk, and shall not be entitled to any compensation for such performance. In addition, the City of Roswell reserves the right to withdraw or cancel the award of the ITB.

### 6.3 Contract Term

---

The term of the contract will be until project completion as specified. Contractor acknowledges that if awarded a contract, the said contract will be non-exclusive and the City of Roswell reserves the right to purchase items in a manner that is in the best interest of the City of Roswell.

Bidders are to bid FOB, Designation. Title to the goods shall remain with vendor until acceptance by the department. All freight and delivery charges must be incorporated as part of the base bid amount. Vendor shall transfer and deliver to the department named all of the goods and/or services described herein for the consideration set forth herein. Risk of loss of the goods shall pass to the department upon acceptance only.

Costing for the combination of materials and labor needed to provide the Exterior Renovations for the Physical Activity Center Building "B" located at Roswell Area Park located at 10495 Woodstock Rd, Roswell, GA 30075 is itemized on the following attached "Cost Bid Form".

All charges shall be included in unit costs.

## 6.4 Contract Termination

---

The City may terminate, by written notice to the Offeror, any resulting contract without cause. The City must give notice of termination to the Offeror at least **30 days** prior to the effective date of termination.

## 6.5 Subcontractors

---

The lowest responsive and responsible Offeror will be the prime contractor, if a contract is awarded, and shall be responsible, in total, for all work of any subcontractors. All subcontractors, if any, must be listed in the bid submission. The City of Roswell reserves the right to approve all subcontractors. The Contractor shall be responsible to the City of Roswell for the acts and omissions of all subcontractors or agents and of persons directly or indirectly employed by such subcontractors, and for the acts and omissions of persons employed directly by the Contractor. Further, nothing contained within this document or any contract documents created as a result of any contract award derived from this ITB shall create any contractual relationships between any subcontractor and the City of Roswell.

## 6.6 Bonding Requirements

---

Each bid must be accompanied with a BID BOND (bond only: certified checks or other forms are not acceptable) in an amount equal to five percent (5%) of the base bid, payable to the City of Roswell. Said bid bond guarantees the Offeror will enter into a contract to construct the project strictly within the terms and conditions stated in this bid and in the bidding and contract documents, should the construction contract be awarded.

The successful Offeror shall be required to furnish a bond for the faithful performance on the contract and a bond to secure payment of all claims for materials furnished and/or labor performed in performance of the project, both in amounts equal to one hundred percent (100%) of the contract price.

Bonds shall be issued by a corporate surety appearing on the Treasury Department's most current list (Circular 570 as amended) and be authorized to do business in the State of Georgia.

Date of Bond must not be prior to date of Contract. If Contractor is a Partnership, all partners shall execute Bond.

## 6.7 General Insurance Requirements

---

The Offeror shall provide the City of Roswell with a certified copy of each of the policies or binders to the address listed under *Section 1.1* indicating the existence of the policies prior to the beginning of the contract term. In the event a binder is delivered, it shall be replaced within ten (10) days by a certified copy of the policy. Each policy shall contain a valid provision or endorsement that the policy may not be canceled without giving thirty (30) days written notice thereof to the City of Roswell representative named in the contract. A renewal policy or certificate shall be delivered to the City of Roswell at least thirty (30) days prior to the expiration date of each expiring policy. If at any time, any of the policies shall be or become unsatisfactory to the City of Roswell as to form or substance, or any of the carriers issuing such policies shall be or become unsatisfactory to the City of Roswell, the Offeror shall deliver to the City of Roswell representative upon demand a certified copy of any

policy required herein for review. **The Certificates of Insurance shall name that the City of Roswell is Additionally Insured.** The fact that insurance is obtained by Contractor shall not be deemed to release or diminish the liability of the Contractor, including without limitation, liability under the indemnity provisions of this Agreement. Damages recoverable by the City of Roswell shall not be limited to the amount of the required insurance coverage.

▪ **Statutory Workers' Compensation Insurance:**

Employers Liability:

- Bodily Injury by Accident \$100,000 each accident
- Bodily Injury by Disease \$500,000 policy limit
- Bodily Injury by Disease \$100,000 each employee

▪ **Comprehensive General Liability Insurance:**

- Each Occurrence Limit \$1,000,000
- Personal & Advertising Injury Limit \$1,000,000
- General Aggregate Limit \$2,000,000
- Products/Completed Ops Aggregate Limit \$2,000,000

▪ **Comprehensive Automobile Liability Insurance:**

- \$1,000,000 limit of liability
- Comprehensive form covering all owned, non-owned and hired vehicles

▪ **Excess Umbrella Liability Insurance:**

- \$3,000,000 limit of liability
- Coverage at least as broad as primary coverage as outlined under Items 1, 2 and 3 above

▪ **Contractor Pollution Liability Insurance:**

- Bodily injury, including death limits of \$1,000,000 for each accident
- Property damage limits of \$2,000,000 for each accident
- \$4,000,000 for the aggregate of operations

**6.8 Compliance with Workers' Compensation Act**

---

The Contractor is required to supply the City of Roswell with proof of compliance with the Workers' Compensation Act while performing work for the City of Roswell. Neither the Contractor nor its employees are employees of the City of Roswell. Proof of compliance must be received at the address listed under *Section 1.1* within acceptable time limits established by the contract. If the Contractor does not meet the State's requirement for workers' compensation coverage, the certificate of insurance shall state that the contractor waives subrogation in regard to workers' compensation.

**6.9 Compliance with Illegal Immigration Reform and Enforcement Act**

---

**E-Verify Program:** The City of Roswell is committed to compliance with federal and state laws requiring the verification of newly hired employees to ensure they are lawfully entitled to work in

the United States. As such, the City of Roswell shall not enter into a contract for the physical performance of services unless the contractor registers and participates in a federal work authorization program (E-Verify). An Offeror should include a fully executed E-Verify affidavit as part of its proposal (Appendix A).

**Requirement to Participate in a Federal Work Authorization Program (E-Verify):**

- (1) Pursuant to O.C.G.A. § 13-10-91:
  - a. Public employers shall not enter into any contract for the physical performance of services within the State of Georgia unless the contractor registers and participates in a federal work authorization program to verify the employment eligibility of all newly hired employees;
  - b. Subcontractors shall not enter into any contract with a contractor for the physical performance of services within the State of Georgia unless such subcontractor registers and participates in a federal work authorization program to verify the employment eligibility of all newly hired employees; and
  - c. Sub-subcontractors shall not enter into any contract with a subcontractor or sub-subcontractor for the physical performance of services within the State of Georgia unless such sub-subcontractor registers and participates in a federal work authorization program to verify the employment eligibility of all newly hired employees.
- (2) As of the date of enactment of O.C.G.A. § 13-10-91, the applicable federal work authorization program is “E-Verify” (<https://e-verify.uscis.gov/enroll/StartPage.aspx?JS=YES>) operated by the United States Citizenship and Immigration Services Bureau of the United States Department of Homeland Security. Information and instructions regarding E-Verify program registration, corporate administrator registration, and designated agent registration can be found at that website address.

**Contractor, Subcontractor, and Sub-subcontractor Evidence of Compliance:**

- (1) Public employers who enter into a contract for the physical performance of services within the State of Georgia shall include in such contract a provision stating that compliance with the requirements of O.C.G.A. § 13-10-91 are conditions of the contract.
- (2) Pursuant to O.C.G.A. §13-10-91, public employers shall include in all covered contracts a provision stating the contractor’s agreement that, in the event the contractor employs or contracts with a subcontractor in connection with the covered contract, the contractor will secure from such subcontractor attestation of the subcontractor’s compliance with O.C.G.A. 13-10-91 by the subcontractor’s execution of the subcontractor affidavit and maintain records of such attestation for inspection by the City of Roswell at any time. Such subcontractor affidavit shall become a part of the contractor/subcontractor agreement.

- (3) Pursuant to O.C.G.A. §13-10-91, public employers shall include in all covered contracts a provision stating the contractor's agreement that, in the event the contractor employs or contracts with a subcontractor that employs or contracts with any sub-subcontractor, the subcontractor will secure from such sub-subcontractor attestation of the sub-subcontractor's compliance with O.C.G.A. § 13-10-91 by the sub-subcontractor's execution of the sub-subcontractor affidavit and maintain records of such attestation for inspection by the City of Roswell at any time. Such sub-subcontractor affidavit shall become a part of the subcontractor/sub-subcontractor agreement.
- (4) All portions of contracts pertaining to compliance with O.C.G.A. § 13-10-91 and these rules, and any affidavit related hereto, shall be open for public inspection in this State at reasonable times during normal business hours.

## 6.10 Compliance with Laws

---

The Offeror must, in performance of work under the contract, fully comply with all applicable federal, state, or local laws, rules and regulations, including, but not limited to, the Civil Rights Act of 1964, the Age Discrimination Act of 1975, the Americans with Disabilities Act of 1990, and Section 504 of the Rehabilitation Act of 1973. Any subletting or subcontracting by the Offeror subjects subcontractors to the same provision. The Offeror agrees that the hiring of persons to perform the contract will be made on the basis of merit and qualifications and there will be no discrimination based upon race, color, religion, creed, political ideas, sex, age, marital status, physical or mental disability, or national origin by the persons performing the contract.

## 6.11 Drug-Free Workplace

---

If Contractor is an individual, he or she hereby certifies that he or she will not engage in the unlawful manufacture, sale, distribution, dispensation, possession, or use of a controlled substance or marijuana during the performance of this contract.

6.11.1 **Certification:** If Contractor is an entity other than an individual, it hereby certifies that:

- i. A drug-free workplace will be provided for the Contractor's employees during the performance of this contract; and
- ii. It will secure from any subcontractor hired to work in a drug-free workplace the following written certification: "As part of the subcontracting agreement with (Contractor's Name), (Subcontractor's Name), certifies to the Contractor that a drug-free workplace will be provided for the subcontractor's employees during the performance of this contract pursuant to paragraph 7 of subsection B of Code Section 50-24-3."

6.11.2 **Penalties:** Contractor may be suspended, terminated, or debarred if it is determined that:

- iii. The Contractor has made false certification hereinabove; or

- iv. The Contractor has violated such certification by failure to carry out the requirements of Official Code of Georgia Section 50-24-3.

#### 6.12 Substitutions and Change Orders

---

NO substitutions of material, schedule cancellations, or change orders are permitted after contract award without written approval by the City Administrator. Where specific employees are proposed by the Offeror for the work, those employees shall perform the work as long as those employees work for the Contractor, either as employees or subcontractors, unless the City of Roswell agrees to a replacement. Requests for any substitution will be reviewed and may be approved by the City of Roswell at its sole discretion. Verbal agreements to the contrary will not be recognized.

#### 6.13 Invoicing and Payment

---

The City of Roswell agrees to pay the Offeror in current funds for the performance of the contract subject to additions and deductions as provided in the General Conditions of the contract. Upon completion of work and acceptance of the item(s) and/or service(s), the Offeror shall submit an invoice detailing the appropriate charges as currently allowed. When all Work is completed and final acceptance has been approved by the City, the Offeror may invoice for the amount retained.

The City will process approved payment requests under this project to the awarded Contractor. Payment to subcontractors and suppliers is the responsibility of the awarded Contractor. The City will not entertain any other payment arrangements.

Invoices shall be submitted to:

Roswell Finance Department  
Attn: Cash Disbursements  
invoices@roswellgov.com  
38 Hill Street  
Roswell, GA 30075

Upon receipt of invoice and inspection and acceptance of the items and services, the City of Roswell will render payment. All such invoices will be paid within thirty (30) days by the City of Roswell unless any items thereon are questioned, in which event payment will be withheld pending verification of the amount claimed and the validity of the claim. The Offeror will provide complete cooperation during any such investigation.

Successful Offeror(s) must provide the City with a completed and signed W-9.

#### 6.14 Taxes

---

No sales tax will be charged on any orders.

#### 6.15 Deliveries

---

In the event there are to be deliveries on site, all goods and materials will be F.O.B. Destination. The onsite delivery address is:

City of Roswell  
Daniel Owens, Project Coordinator  
Roswell Area Park, Physical Activity Center, Building "B"  
10495 Woodstock Rd  
Roswell GA 30075

No freight or postage charges will be paid by the City of Roswell unless such charges are included and accepted in the bid price and awarded by contract. The Offeror, at Offeror's expense, will arrange to have someone onsite to inspect and accept delivery. The Offeror has sole responsibility for securing all materials at the project site. Offeror shall transfer and deliver to the department named all of the goods and/or services described in this bid for the consideration set forth herein. Risk of loss of the goods shall pass to the department upon acceptance only. Title to the goods shall remain with vendor until acceptance by the department.



## Appendix A – Standard Forms

---

This section contains the forms necessary to ensure compliance with various laws as described within this ITB.

Please complete, sign, and return each of the following forms with the bid submittal:

- Cost Bid Form
- Bid Bond
- References
- List of Subcontractors
- Corporate Certificate
- Affidavit Verifying Contractor Participation in Federal Work Authorization Program (E-Verify)

For your reference

- Sample Contract
- Performance Bond
- Payment Bond

# Exhibit A - COST BID FORM

---

**TO:** BUYER OF RECORD  
CITY OF ROSWELL  
ROSWELL, GEORGIA 30075

**To Whom It May Concern:**

In compliance with your Invitation To Bid, the undersigned, hereinafter termed the Bidder, proposes to enter into a Contract with the City of Roswell, Georgia, to provide the necessary machinery, tools, apparatus, other means of construction, and all materials and labor specified in the Contract Documents or as necessary to complete the Work in the manner therein specified within the time specified, as therein set forth, for:

**ITB NUMBER 16-259-L**  
**Roswell Area Park Physical Activity Center Building B**  
**Exterior Renovations**

The Offeror has carefully examined and fully understands the Contract, Specifications, Plans, and other documents hereto attached, has made a personal examination of the Site of the proposed Work, has satisfied himself as to the actual conditions and requirements of the Work, and hereby proposes and agrees that if his bid is accepted, he will contract with the City of Roswell in full conformance with the Contract Documents.

It is the intent of this Bid to include all items of construction and all Work indicated called for in the Specifications, or otherwise a part of the Contract.

In accordance with the foregoing, the undersigned proposes to furnish and construct the items listed in the attached Bid schedule for the unit prices stated.

The Offeror agrees that the cost of any work performed, materials furnished, services provided or expenses incurred, which are not specifically delineated in the Contract Documents but which are incidental to the scope, intent, and completion of the Contract, shall be deemed to have been included in the prices bid for the various items scheduled.

The Offeror further proposes and agrees hereby to promptly commence the Work with adequate forces and equipment within ten (10) calendar days from receipt of Notice to Proceed and to complete all Work within 180 calendar days thereafter.

Offeror agrees that the provisions of the City of Roswell Vendor Manual are incorporated herein by reference and made a part hereof just as if it had been fully set out herein. Provided, however, that in the event of a conflict between the terms and conditions contained therein and the terms and conditions of this Contract, the latter shall govern.

Bidder agrees that from the date this Invitation to Bid is issued until an award is made, bidders **are not allowed to communicate with any staff or elected officials of the City regarding this procurement**. Any unauthorized contact may disqualify the bidder from further consideration. Contact information for the single point of contact is as follows:

Buyer: Lynn Shriner  
Address: 38 Hill Street  
Roswell, GA 30075  
Telephone Number: 770-641-3718  
E-mail Address: [purchasing@roswellgov.com](mailto:purchasing@roswellgov.com)

**Bidder has carefully examined the Bidding Documents entitled:  
Roswell Area Park Physical Activity Center, Building B, Exterior Renovations  
Bid Number: ITB NUMBER 16-259-L September 15, 2016**

**Acknowledges receipt of the following addenda numbers and dates, if any:**

\_\_\_\_\_;

**And has examined the premises and conditions affecting the Work, the undersigned proposes to furnish all services, labor and materials called for by them for the Base Bid Work, in accordance with said documents, for the sum of: (Include the additional charges or fees that would apply to any delivery of product.**

ANY DEVIATION FROM SPECIFICATIONS MUST BE COMPLETELY EXPLAINED BY BIDDER.  
Bidder will explain exact particulars where bid does not meet exactly the specification.

\_\_\_\_\_  
\_\_\_\_\_

Bidder further declares that the full name and business address of Bidder's Principal is as follows:

\_\_\_\_\_  
\_\_\_\_\_

Signed, sealed, and dated this \_\_\_\_\_ day of \_\_\_\_\_

Bidder \_\_\_\_\_ (Seal)

Company Name

Bidder Mailing Address: \_\_\_\_\_

\_\_\_\_\_

By: \_\_\_\_\_

Title: \_\_\_\_\_

Phone: \_\_\_\_\_

E-Mail: \_\_\_\_\_

# BID BOND

---

KNOW ALL MEN BY THESE PRESENTS, THAT \_\_\_\_\_ (Name  
of Contractor) \_\_\_\_\_ (Address  
of

Contractor) a \_\_\_\_\_

(Corporation, Partnership and or Individual) hereinafter called Principal, and \_\_\_\_\_

\_\_\_\_\_  
(Name of Surety)

\_\_\_\_\_  
(Address of Surety)

a corporation of the State of \_\_\_\_\_, and a surety authorized by law to do business in the State of Georgia, hereinafter called Surety, are held and firmly bound unto

City of Roswell Georgia

(Name of Obligee)

38 Hill Street Suite 235, Roswell Georgia 30075

(Address of Obligee)

herein after referred to as Obligee, in the penal sum of \_\_\_\_\_ Dollars (\$ \_\_\_\_\_) in lawful money of the United States, for the payment of which sum well and truly to be made, we bind ourselves, our heirs, executors, administrators and successors, jointly and severally, firmly by these presents.

WHEREAS, the Principal is about to submit, or has submitted, to the City of Roswell, Georgia, a proposal for furnishing materials, labor, and equipment for:

---

WHEREAS, the Principal desires to file this Bond in accordance with law in lieu of a certified Bidder's check otherwise required to accompany this Proposal.

NOW, THEREFORE, the conditions of this obligation are such that if the bid is accepted, the Principal shall within ten days after receipt of notification of the acceptance execute a Contract in accordance with the Bid and upon the terms, conditions, and prices set forth in the form and manner required by the City of Roswell, Georgia, and execute a sufficient and satisfactory Performance Bond and Payment Bond payable to the City of Roswell, Georgia, each in an amount of 100% of the total Contract Price, in form and with security satisfactory to said the City of Roswell, Georgia, and otherwise, to be and remain in full force and virtue in law; and the Surety shall, upon failure of the Principal to comply with any or all of the foregoing requirements within the time specified above, immediately pay to the City of Roswell,

Georgia, upon demand, the amount hereof in good and lawful money of the United States of America, not as a penalty, but as liquidated damages.

PROVIDED, FURTHER, that Principal and Surety agree and represent that this bond is executed pursuant, to and in accordance with the applicable provisions of the Official Code of Georgia Annotated, as Amended, including, but not limited to, O.C.G.A. SS 13-10-1, et. seg. and SS 36-86-101, et. seg. and is intended to be and shall be constructed as a bond in compliance with the requirements thereof.

Signed, sealed, and dated this \_\_\_\_\_ day of \_\_\_\_\_ A.D., 20\_\_\_\_

ATTEST:

\_\_\_\_\_  
(Principal Secretary)

\_\_\_\_\_  
(Principal)

(SEAL)

BY: \_\_\_\_\_

\_\_\_\_\_  
(Witness to Principal)

\_\_\_\_\_  
(Address)

\_\_\_\_\_  
(Address)

\_\_\_\_\_  
(Surety)

ATTEST

BY: \_\_\_\_\_  
(Attorney-in-Fact) and Resident Agent

\_\_\_\_\_  
(Attorney-in-Fact)

(Seal) \_\_\_\_\_  
(Address)

\_\_\_\_\_  
(Witness as to Surety)

\_\_\_\_\_  
(Address)

**NOTE:** Date of Bond must not be prior to date of Contract. If Contractor is a Partnership, all partners should execute Bond.

## REFERENCES

---

**REFERENCES:** Please provide the City with the last five (5) clients of similar size and scope. You may submit your standard list of references as opposed to using this form, but you still need to complete and sign at the bottom.

**REFERENCE # 1**

Name of Entity/Firm: \_\_\_\_\_

Mailing Address: \_\_\_\_\_

City/State/Zip Code: \_\_\_\_\_

Contact Person Name: \_\_\_\_\_

Contact Person Telephone Number: \_\_\_\_\_

Email Address: \_\_\_\_\_

Date When Work Performed: \_\_\_\_\_

Description of Work Performed: \_\_\_\_\_

\_\_\_\_\_

\_\_\_\_\_

**REFERENCE # 2**

Name of Entity/Firm: \_\_\_\_\_

Mailing Address: \_\_\_\_\_

City/State/Zip Code: \_\_\_\_\_

Contact Person Name: \_\_\_\_\_

Contact Person Telephone Number: \_\_\_\_\_

Email Address: \_\_\_\_\_

Date When Work Performed: \_\_\_\_\_

Description of Work Performed: \_\_\_\_\_

**REFERENCE # 3**

Name of Entity/Firm: \_\_\_\_\_

Mailing Address: \_\_\_\_\_

City/State/Zip Code: \_\_\_\_\_

Contact Person Name: \_\_\_\_\_

Contact Person Telephone Number: \_\_\_\_\_

Email Address: \_\_\_\_\_

Date When Work Performed: \_\_\_\_\_

Description of Work Performed: \_\_\_\_\_

\_\_\_\_\_  
\_\_\_\_\_

**REFERENCE # 4**

Name of Entity/Firm: \_\_\_\_\_

Mailing Address: \_\_\_\_\_

City/State/Zip Code: \_\_\_\_\_

Contact Person Name: \_\_\_\_\_

Contact Person Telephone Number: \_\_\_\_\_

Email Address: \_\_\_\_\_

Date When Work Performed: \_\_\_\_\_

Description of Work Performed: \_\_\_\_\_

\_\_\_\_\_  
\_\_\_\_\_

**REFERENCE # 5**

Name of Entity/Firm: \_\_\_\_\_

Mailing Address: \_\_\_\_\_

City/State/Zip Code: \_\_\_\_\_

Contact Person Name: \_\_\_\_\_

Contact Person Telephone Number: \_\_\_\_\_

Email Address: \_\_\_\_\_

Date When Work Performed: \_\_\_\_\_

Description of Work Performed: \_\_\_\_\_

\_\_\_\_\_

\_\_\_\_\_



# LIST OF SUBCONTRACTORS

---

I do \_\_\_\_\_, do not \_\_\_\_\_, propose to subcontract some of the work on this project. I propose to Subcontract work to the following subcontractors:

SUBCONTRACTOR	WORK TO BE PERFORMED	% OF THE WORK

Company Name: \_\_\_\_\_

**\* The City of Roswell requires 51% participation by the prime Contractor on all projects.**

## CORPORATE CERTIFICATE

---

I, \_\_\_\_\_, certify that I am the Secretary of the Corporation

named as Contractor on the foregoing bid; that \_\_\_\_\_

who signed said bid in behalf of the Contractor, was then (title) \_\_\_\_\_  
of

said Corporation; that said bid was duly signed for and on behalf of said Corporation by  
authority

of its Board of Directors, and is within the scope of its corporate powers; that said

Corporation is organized under the laws of the State of

\_\_\_\_\_.

This \_\_\_\_\_ day of \_\_\_\_\_, 20\_\_\_\_\_

\_\_\_\_\_(Seal)  
(Signature)

# AFFIDAVIT VERIFYING CONTRACTOR PARTICIPATION IN FEDERAL WORK AUTHORIZATION PROGRAM

---

By executing this affidavit, the undersigned contractor verifies its compliance with O.C.G.A. § 13-10-91, stating affirmatively that the individual, firm or corporation which is engaged in the physical performance of services on behalf of the **City of Roswell (GA)** has registered with, is authorized to use and uses the federal work authorization program commonly known as E-Verify, or any subsequent replacement program, in accordance with the applicable provisions and deadlines established in O.C.G.A. § 13-10-91. Furthermore, the undersigned contractor will continue to use the federal work authorization program throughout the contract period and the undersigned contractor will contract for the physical performance of services in satisfaction of such contract only with subcontractors who present an affidavit to the contractor with the information required by O.C.G.A. § 13-10-91(b).

Contractor hereby attests that its federal work authorization user identification number and date of authorization are as follows:

\_\_\_\_\_  
Federal Work Authorization (E-Verify) User Identification Number

\_\_\_\_\_  
Date of Authorization

\_\_\_\_\_  
Name of Contractor

\_\_\_\_\_  
Name of Project

I hereby declare under penalty of perjury that the foregoing is true and correct.

Executed on \_\_\_\_\_, \_\_\_\_\_, 201\_\_ in \_\_\_\_\_ (city), \_\_\_\_\_ (state).

\_\_\_\_\_  
Signature of Authorized Officer or Agent

\_\_\_\_\_  
Printed Name and Title of Authorized Officer or Agent

SUBSCRIBED AND SWORN BEFORE ME ON THIS THE \_\_\_\_ DAY OF \_\_\_\_\_, 201\_\_.

NOTARY PUBLIC

My Commission Expires:

\_\_\_\_\_

## CONTRACT AGREEMENT

---

This Contract for **Bid 16-259-L for Roswell Area Park Physical Activity Center, Building “B” Exterior Renovations** (the “Project”) is made as of the Execution Date by and between \_\_\_\_\_, (“Contractor”) and The **City of Roswell** (“City”). Contractor and City may be referred to individually as a “Party” or collectively as the “Parties”.

### CONTRACT:

NOW, THEREFORE, for and in consideration of the mutual promises contained herein and other good and valuable consideration, the receipt and sufficiency of which are hereby acknowledged, the Parties agree as follows:

1. The CONTRACTOR shall furnish all material, labor, equipment, and tools necessary for the Project located in Roswell, GA, as well as all work incidental and pertinent thereto all in accordance with the Contract (hereinafter designated the “CONTRACT”); **Bid 16-259-L for Roswell Area Park Physical Activity Center, Building “B” Exterior Renovations** (hereinafter designated the “Proposal”), a copy of which is attached hereto as Exhibit A and incorporated herein; and the **CONTRACTOR’S Response to Bid 16-259-L for Roswell Area Park Physical Activity Center, Building “B” Exterior Renovations** (Exhibit B) (hereinafter designated the “Response”). In the event of any conflict, ambiguity, or inconsistency between the terms contained in this CONTRACT and the Exhibits, the terms set forth in this CONTRACT shall govern and control.
2. The term of the CONTRACT shall begin on the Execution Date and shall be for the duration of the project, unless sooner terminated as permitted herein, or unless extended by agreement of the parties set forth in writing. The CONTRACTOR is required to submit to the City a Certificate of Insurance prior to commencing work. In addition, the work shall be scheduled as agreed upon by the parties. Work shall commence with adequate force and equipment within ten (10) days from the Notice to Proceed from the City and shall be completed within the specified time as defined within the project manual.

### 3. Pricing

The City shall pay the CONTRACTOR for the CONTRACTOR’S performance in accordance with the amounts established in CONTRACTOR’S Completed Cost Bid Form or the amount finally awarded by City (\$ \_\_\_\_\_). The City shall pay the Contractor in accordance with the prices stipulated in the Bid Schedule based upon verified quantities. No price adjustments shall be made during the term or any extension of this Contract except upon mutual consent of the parties. The contractor shall invoice the City on a monthly basis for actual quantities completed.

### 4. Termination

(a) *Termination by City:* City may at its sole option terminate this CONTRACT by giving the CONTRACTOR thirty (30) days written notice. Should the CONTRACTOR fail to fulfill in a timely and proper manner its obligations under this CONTRACT or if it should violate any of the terms of this

CONTRACT, the City shall have the right to immediately terminate the CONTRACT. Such termination shall not relieve CONTRACTOR of any liability to the City for damages sustained by virtue of any breach by CONTRACTOR. A reasonable period of time to cure a CONTRACTOR breach of CONTRACT can be negotiated with the CONTRACTOR selected.

(b) *Termination by CONTRACTOR.* If at any time or from time to time during the Term, any of the following events shall occur and not be remedied within the applicable period of time herein specified, namely:

(i) City shall materially fail to keep, observe or perform any covenant, agreement, term or provision of this CONTRACT to be kept, observed or performed by City, and such default shall continue for a period of sixty (60) days after written notice thereof by CONTRACTOR to City, which shall specify such failure with particularity.

(c) *Continuing Obligations.* If this CONTRACT is terminated pursuant to this Section 4, the Parties shall account for and pay to the other all sums due and owing pursuant to the terms of this CONTRACT within thirty (30) days after the effective date of termination.

(d) *Force Majeure.* Neither Party shall be liable for any loss, damage, delay or nonperformance of any Services as a result of causes not reasonably within the control of such Party including, but not limited to, acts of God, terrorism, war, riot, insurrection, civil violence or disobedience, blockages, embargoes, sabotage, epidemics, fire, strikes, lock-outs or other industrial or labor disturbances, lighting, hurricanes, cyclonic storms, and explosions; provided, however, that the affected Party notifies the other Party promptly of the occurrence of the cause and thereafter exerts commercially reasonable efforts to overcome the cause of the prevention or hindrance if such cause is within the Party's reasonable control, and to resume performance.

## 5. Representations and Warranties

(a) *Representations by CONTRACTOR.* CONTRACTOR hereby represents and warrants to City that:

(i) CONTRACTOR is a not for profit company duly organized, validly existing and in good standing under the laws of the State of Georgia, is duly qualified to conduct business in the State of Georgia and has the requisite power and authority to enter into this CONTRACT and perform its obligations hereunder.

(ii) CONTRACTOR has all requisite power and authority to enter into and perform this CONTRACT and to perform each of its obligations under this CONTRACT. This CONTRACT and the transactions contemplated by this CONTRACT have been duly and validly authorized by all necessary action on the part of CONTRACTOR.

(iii) This CONTRACT has been duly executed and delivered by CONTRACTOR and constitutes the legal, valid and binding obligation of CONTRACTOR, enforceable against CONTRACTOR in accordance with its terms, except to the extent that its enforceability may be limited by bankruptcy, insolvency and other applicable laws affecting creditors' rights generally.

(iv) The execution and delivery of this CONTRACT by CONTRACTOR does not, and the consummation of the transactions contemplated herein will not (i) result in the breach of any

of the terms and conditions of, or constitute a default with respect to or result in the acceleration of any indebtedness or create liability under any material contract, agreement, commitment, indenture, mortgage, note, bond, lease, license or other instrument or obligation to which CONTRACTOR is now a party or by which CONTRACTOR may be bound or affected; or (ii) violate any law or any rule or regulation of any administrative agency or governmental body, or any order, writ, injunction or decree of any court, administrative agency or governmental body. The execution and delivery of this CONTRACT, do not, and will not constitute a material default under any organization or governing agreement relating to CONTRACTOR.

(b) *Representations by City.* City hereby represents and warrants to CONTRACTOR as follows:

(i) City is duly organized, validly existing and in good standing under the laws of the State of Georgia, is duly qualified to conduct business in the State of Georgia and has the requisite power and authority to enter into this CONTRACT and perform its obligations hereunder.

(ii) City has all requisite power and authority to enter into and perform this CONTRACT and to perform each of its obligations under this CONTRACT. This CONTRACT and the transactions contemplated by this CONTRACT have been duly and validly authorized by all necessary action on the part of City.

(iii) This CONTRACT has been duly executed and delivered by City and constitutes the legal, valid and binding obligation of City, enforceable against City in accordance with its terms, except to the extent that its enforceability may be limited by bankruptcy, insolvency and other applicable laws affecting creditors' rights generally.

(iv) The execution and delivery of this CONTRACT by City does not, and the consummation of the transactions contemplated herein will not (i) result in the breach of any of the terms and conditions of, or constitute a default with respect to or result in the acceleration of any indebtedness or create liability under any material contract, agreement, commitment, indenture, mortgage, note, bond, lease, license or other instrument or obligation to which City is now a party or by which City may be bound or affected; or (ii) violate any law or any rule or regulation of any administrative agency or governmental body, or any order, writ, injunction or decree of any court, administrative agency or governmental body. The execution and delivery of this CONTRACT, do not, and will not constitute a material default under any organization or governing agreement relating to City

(c) *Disclaimer of Warranties.* Other than as specifically set forth herein, neither of the Parties makes any representations, warranties or guarantees, express or implied, directly or indirectly, including, but not limited to, any warrant of merchantability or fitness for a particularly purpose.

## 6. Indemnification

CONTRACTOR hereby agrees to hold harmless and indemnify City, and its employees, agents, representatives, successors and assigns from and against any and all losses, liabilities, damages, demands, claims, suits, actions, causes of action, judgments, assessments, costs and expenses, including, without limitation, interest, penalties, reasonable attorneys' fees, any and all expenses incurred in investigating, preparing or defending against any litigation, commenced or threatened,

or any claim whatsoever, and any and all amounts paid in settlement of any claim or litigation (collectively, "Damages"), asserted against, resulting to, imposed upon, or incurred or suffered by of them, directly or indirectly, as a result of, arising from, or relating directly or indirectly to: (i) any inaccuracy in or any breach or nonfulfillment of any of the representations or warranties made by CONTRACTOR in this Agreement; (ii) any breach or nonfulfillment of any of the covenants or agreements made by CONTRACTOR in this CONTRACT; or (iii) any violations of law by CONTRACTOR in performing its obligations under this CONTRACT.

7. Insurance

The CONTRACTOR, at all times that this CONTRACT is in force, agrees to provide, as a minimum, worker's compensation, commercial general liability, and automobile liability insurance coverage in accordance with the Insurance Requirements provided in Section 6.7 of ITB 14-318-R.

8. Compliance with All Laws and Licenses

The Contractor must obtain all necessary licenses and comply with local, state and federal requirements. The Contractor shall comply with all laws, rules and regulations of any governmental entity pertaining to its performance under this CONTRACT.

9. Assignment

The Contractor shall not assign or subcontract the whole or any part of this CONTRACT without the City of Roswell's prior written consent.

10. Amendments in Writing

No amendments to this CONTRACT shall be effective unless it is in writing and signed by duly authorized representatives of the parties.

11. Policy on Hiring of Non-Resident Aliens

The final award of a contract is contingent upon compliance with O.C.G.A. 13-10-91 and Chapter 300-10-1 of the Rules of the Georgia Department of Labor, and the Contractor certifying to the City that it, and all its subcontractors, has registered and currently participates in the federal work authorization program to verify information of all new employees with respect to all public employers, contractors, or subcontractors. Contractor may be suspended, terminated, or debarred if it is determined that the Contractor has made false certification or that the Contractor has violated such certification by failure to carry out this requirement.

12. Inclusion of Documents, Exhibits

Bid 16-259-L for Roswell Area Park Physical Activity Center, Building "B" Exterior Renovations , all plans, project manuals, addendums and the Contractor's proposal submitted in response thereto, including any best and final offer, are incorporated in this CONTRACT; form an integral part of this CONTRACT; and, are attached hereto as Exhibits A and B.

In the event of a conflict in language between this CONTRACT and the foregoing documents incorporated herein, the provisions and requirements set forth in this CONTRACT shall govern. In

the event of a conflict between the languages of the Contractor's proposal, the language in the former shall govern.

### 13. General Provisions

(a) *Governing Law/Jurisdiction.* This CONTRACT is entered into in the State of Georgia and shall be construed in accordance with the laws of the State of Georgia, without regard to its choice of law provisions. The Parties further irrevocably consent and agree that the Superior Court of Fulton County, Georgia shall be the exclusive jurisdiction for any action or dispute arising out of this CONTRACT and the Parties hereby consent to venue in said court.

(b) *Severability.* If any provision of this CONTRACT is held invalid or unenforceable by any court of competent jurisdiction, the other provisions of this CONTRACT will remain in full force and effect. Any provision of this CONTRACT held invalid or unenforceable only in part or degree will remain in full force and effect to the extent not held invalid or unenforceable.

(c) *Waiver.* Neither the failure nor any delay by any Party in exercising any right, power, or privilege under this CONTRACT will operate as a waiver of such right, power, or privilege, and no single or partial exercise of any such right, power, or privilege will preclude any other or further exercise of such right, power, or privilege or the exercise of any other right, power, or privilege.

(d) *Survival.* Except to the extent provided to the contrary in this CONTRACT, no termination of this CONTRACT shall in any way effect or impair the power, obligation, duties, rights and liabilities of the Parties relating to (i) any transaction or event occurring prior to such termination or (ii) any of the undertakings, CONTRACTS, covenants, warranties and representations of the parties with respect to (i) or (ii) above. All such undertakings, agreements, covenants, warranties and representations shall survive such termination or cancellation of this CONTRACT, including return of unearned cancellation obligations owed by the Parties.

(e) *Successors and Assigns.* This CONTRACT shall not be assigned without express written consent of the other party. This CONTRACT shall be binding not only on the Parties, but also on their heirs, representatives, administrators, executors, successors and, if approved, assigns, and the parties agree for themselves, and their heirs, administrators, executors, successors and assigns, to execute any and all documents which may be necessary or proper to carry out or effectuate the purpose and intent of this CONTRACT.

(f) *Independent CONTRACTOR.* Nothing herein shall be construed to create a partnership or joint venture between the Parties hereto and neither Party shall be liable in any manner for the debts, obligations or liabilities of the other Party.

(g) *Third-Party Beneficiaries.* Except as specifically provided herein, this CONTRACT shall not create or be construed to create in any manner whatsoever, any rights in any person as a third party beneficiary of this CONTRACT or otherwise.

(h) *Further Assurances.* Each Party agrees to do all acts and things and to make, execute and deliver such written instruments as may from time to time be reasonably required to carry out the terms and provisions of this CONTRACT.



(i) *Counterparts*. This CONTRACT may be executed in one or more counterparts, each of which will be deemed an original copy, but all of which together constitute one and the same instrument.

(j) *Rules of Construction*. All references herein to the singular shall include the plural, and vice versa, and all references herein to the neuter shall include the masculine or feminine, as the case may be, and vice versa. When general words or terms are used herein followed by the word “including” (or another form of the word “include”) and words of particular and specific meaning, the general words shall be construed in their widest extent, and shall not be limited to persons or things of the same general kind or class as those specifically mentioned in the words of particular and specific meaning. No provision of this CONTRACT shall be construed against or interpreted to the disadvantage of a party by reason of such Party having or being deemed to have drafted, structured or dictated such provisions.

(k) *Entire CONTRACT*. This CONTRACT, together with all attachments and exhibits thereto, constitutes the entire agreement between the Parties. The CONTRACT supersedes all prior discussions and agreements between the Parties with respect to the subject matter contained herein, and this CONTRACT contains the sole and entire understanding between the Parties with respect to the transaction contemplated hereby. This CONTRACT may not be modified or amended except by an instrument in writing signed by or on behalf of the Parties.

IN WITNESS WHEREOF, the parties hereto have caused this CONTRACT to be duly executed by their duly authorized officers as of the day and year set forth next to each signature.

**CONTRACTOR:**

**CITY:**

**BY:** \_\_\_\_\_

**BY:** \_\_\_\_\_

**TITLE:** \_\_\_\_\_

**TITLE:** \_\_\_\_\_

**ATTEST:** \_\_\_\_\_

**ATTEST:** \_\_\_\_\_

Executed in Triplicate: Copy \_\_\_\_\_ of 3.

**PERFORMANCE BOND**

KNOW ALL MEN BY THESE PRESENTS:

THAT \_\_\_\_\_  
(Name of Contractor)

\_\_\_\_\_  
(Address of Contractor)

a \_\_\_\_\_  
(Corporation, Partnership or Individual)

Hereinafter called Principal, and

\_\_\_\_\_  
(Name of Surety)

\_\_\_\_\_  
(Address of Surety)

a Corporation of the State of \_\_\_\_\_ and a surety authorized by law to do business in the State of Georgia, hereinafter called Surety, are held and firmly bound unto

The City of Roswell, Georgia  
(Name of Obligee)

38 Hill Street Suite 130, Roswell Georgia 30075  
(Address of Obligee)

hereinafter referred to as Obligee; are held firmly bound unto said Obligee and all persons doing work or furnishing skill, tools, machinery, supplies, or material under or for the purpose of the Contract hereinafter referred to, in the penal sum of:

\_\_\_\_\_ Dollars (\$ \_\_\_\_\_ ) in lawful money of the United States, for the payment of which sum well and truly to be made, we bind ourselves, our heirs, executors, administrators and successors, jointly and severally, firmly by these presents.

The condition of this obligation is such, as whereas the Principal entered into a certain contract, hereto attached, with the Obligee, dated: \_\_\_\_\_

NOW THEREFORE, the conditions of this obligation are such that if the above bound Principal shall well, truly, fully and faithfully perform said contract according to its terms, covenants, conditions, and agreements of said contract during the original term of said contract and any extensions thereof that may be granted by the obligee, with or without notice to the Surety, and during the life of any guaranty required under the contract, and shall also well and truly perform and fulfill all the undertakings, covenants, terms, conditions and agreement of any and all duly authorized modifications of said contract that may hereafter be made, then his obligation shall be void, otherwise to remain in full force and effect.

PROVIDED FURTHER, that said Surety to this Bond, for value received, hereby stipulates and agrees that no change, extension of time, alterations, or additions to the terms of the Contract or to the

Work to be performed thereunder shall in any way affect its obligation on this bond, and it does hereby waive notice of any such change, extension of time, alterations, or additions to the terms of the Contract or to the work to be performed thereunder.

PROVIDED, FURTHER, that Principal and Surety agree and represent that this bond is executed pursuant to and in accordance with the applicable provisions of the Official Code of Georgia Annotated, as Amended, including but not limited to, O.C.G.A. SS 13-10-1 et. eq. and SS 36-86-101, et. seg., and is intended to be and shall be construed as a bond in compliance with the requirements thereof.

Signed, sealed, and dated this \_\_\_\_\_ day of \_\_\_\_\_ A.D., 20\_\_\_\_

ATTEST:

\_\_\_\_\_  
(Principal Secretary)

\_\_\_\_\_  
(Principal)

(SEAL)

BY: \_\_\_\_\_

\_\_\_\_\_  
(Witness to Principal)

\_\_\_\_\_  
(Address)

\_\_\_\_\_  
(Address)

\_\_\_\_\_  
(Surety)

ATTEST

BY: \_\_\_\_\_  
(Attorney-in-Fact) and Resident Agent

\_\_\_\_\_  
(Attorney-in-Fact)  
(Seal)

\_\_\_\_\_  
(Address)

\_\_\_\_\_  
**(Witness as to Surety)**

\_\_\_\_\_  
(Address)

**PAYMENT BOND**

KNOW ALL MEN BY THESE PRESENTS: THAT \_\_\_\_\_

\_\_\_\_\_  
(Name of Contractor)

\_\_\_\_\_  
(Address of Contractor)

a \_\_\_\_\_  
(Corporation, Partnership or Individual)

hereinafter called Principal, and

\_\_\_\_\_  
(Name of Surety)

\_\_\_\_\_  
(Address of Surety)

a Corporation of the State of \_\_\_\_\_ and a surety authorized by law to do business in the State of Georgia, hereinafter called Surety, are held and firmly bound unto

The City of Roswell Georgia  
(Name of Obligee)

38 Hill Street Suite 235, Roswell Georgia 30075  
(Address of Obligee)

hereinafter referred to as Obligee; for the use and protection of all subcontractors and all persons supplying labor, services, skill, tools, machinery, materials and/or equipment in the prosecution of the work provided for in the contract herein after referred to in the full and just sum of \_\_\_\_\_ Dollars (\$\_\_\_\_\_) in lawful money of the United States, for the payment of which sum well and truly to be made, the Principal and Surety bind themselves, their, and each of their heirs, executors, administrators, successors and assigns, jointly and severally, firmly by these presents.

The condition of this obligation is such, as whereas the Principal entered into a certain contract. hereto attached, with the Obligee, dated \_\_\_\_\_ for \_\_\_\_\_.

NOW, THEREFORE, the conditions of this obligation are such that if the Principal shall well, truly, and faithfully perform said Contract in accordance to its terms, covenants, and conditions, and shall promptly pay all persons furnishing labor, materials, services, skill, tools, machinery and/or equipment for use in the performance of said Contract, then this obligation shall be void; otherwise, it shall remain in full force and effect.

All persons who have furnished labor, materials, services, skill, tools, machinery and/or equipment for use in the performance of said Contract shall have a direct right of action on this Bond, provided payment has not been made in full within ninety (90) days after the last day on which labor was performed, materials, services, skill, tools, machinery, and equipment furnished or the subcontract completed.

PROVIDED FURTHER, that said Surety to this Bond, for value received, hereby stipulates and agrees that no change, extension of time, alterations, or additions to the terms of the Contract or to the Work to be performed thereunder shall in any way affect its obligation on this bond, and it does hereby waive notice of any such change, extension of time, alterations, or additions to the terms of the Contract or to the work to be performed thereunder.

PROVIDED, HOWEVER, that no suit or action shall be commenced hereunder by any person furnishing labor, materials, services, skill, tools, machinery, and/or equipment having a direct contractual relationship with a subcontractor, but no contractual relationship express or implied with the Principal:

Unless such person shall have given notice to the Principal within Ninety (90) days after such person did, or performed the last of the work or labor, or furnished the last of the materials, services, skill, tools, machinery and/or equipment for which claim is made, stating with substantial accuracy the amount claimed and the name of the party to whom the materials, services, skill, tools, machinery and/or equipment were furnished, or for whom the work or labor was done or performed. Such a notice shall be served by mailing the same by registered mail, postage prepaid, in an envelope addressed to the Principal, at any place where an office is regularly maintained for the transaction of business, or served in any manner in which legal process may be served in the State in which the aforesaid project is located, save that such service need not be made by a public officer, and a copy of such notice shall be delivered to the Obligee, to the person and at the address provided for in the Contract, within five (5) days of the mailing of the notice to the Principal.

PROVIDED, FURTHER, that any suit under this bond must be instituted before the expiration of one (1) year after the acceptance of the public works covered by the Contract by the proper authorities.

PROVIDED, FURTHER, that Principal and Surety agree and represent that this bond is executed pursuant to and in accordance with the applicable provisions of the Official Code of Georgia Annotated, as Amended, including, but not limited to, O.C.G.A. SS 13-10-1, et. eq. and SS 36-86-101, et. seg., and is intended to be and shall be construed as a bond in compliance with the requirements thereof.

Signed, sealed, and dated this \_\_\_\_\_ day of \_\_\_\_\_ A.D. 20\_\_\_\_

ATTEST:

\_\_\_\_\_  
(Principal Secretary)

\_\_\_\_\_  
(Principal)

(SEAL)

BY: \_\_\_\_\_

\_\_\_\_\_  
(Witness to Principal)

\_\_\_\_\_  
(Address)

\_\_\_\_\_  
(Address)

\_\_\_\_\_  
(Surety)

ATTEST

BY: \_\_\_\_\_  
(Attorney-in-Fact) and Resident Agent

\_\_\_\_\_  
(Attorney-in-Fact)  
(Seal)

\_\_\_\_\_  
(Address)

\_\_\_\_\_  
**(Witness as to Surety)**

\_\_\_\_\_  
(Address)

\_\_\_\_\_

# Attachment Plans

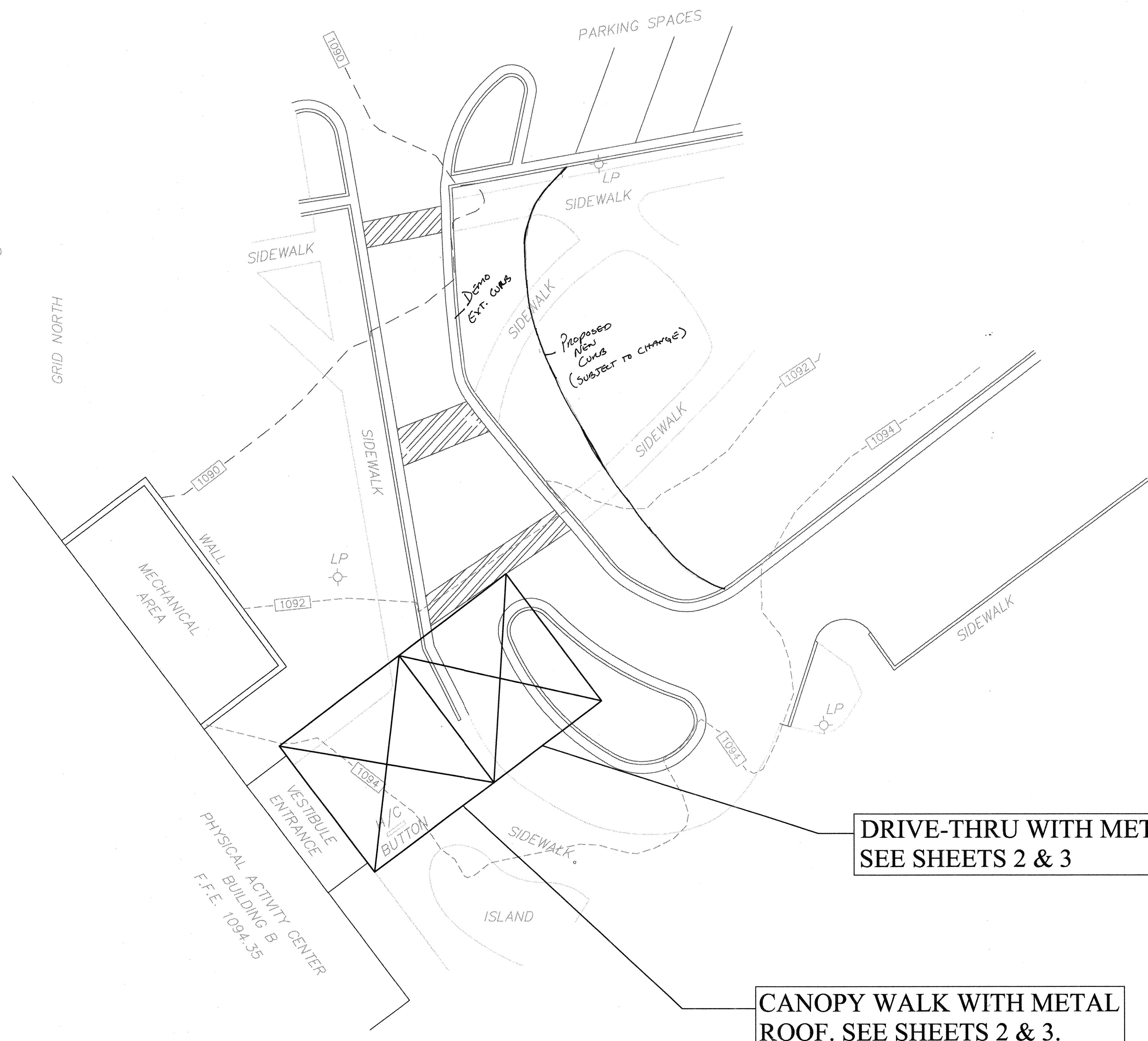
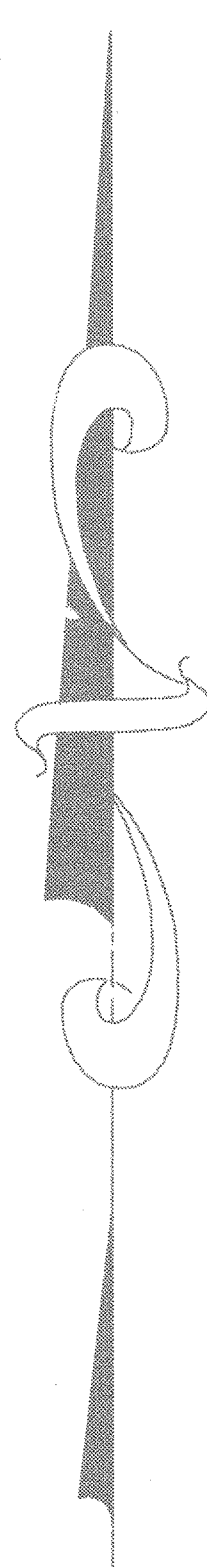

NOTES:

1. THIS SURVEY WAS PREPARED BY FOOTHILLS LAND SURVEYING, LLC LOCATED AT 164 HIGHLANDS DRIVE, WOODSTOCK, GA 30188 PH: (678) 533-8637.
2. INFORMATION REGARDING THE REPUTED PRESENCE, SIZE, CHARACTER, AND LOCATION OF EXISTING UNDERGROUND UTILITIES AND STRUCTURES IS SHOWN HEREON. THE LOCATION AND ARRANGEMENT OF UNDERGROUND UTILITIES AND STRUCTURES SHOWN HEREON MAY BE INACCURATE AND UTILITIES AND STRUCTURES NOT SHOWN MA BE ENCOUNTERED. IT IS THE CONTRACTOR'S RESPONSIBILITY TO LOCATED ALL UNDERGROUND UTILITIES AND STRUCTURES PRIOR TO CONSTRUCTION.
3. FOR PLANS, SECTIONS AND DETAILS OF THE DRIVE-THRU WITH METAL ROOF AND THE CANOPY WALK WITH METAL ROOF SEE SHEETS 2 & 3.

OWNER'S REPRESENTATIVE AND 24 HR. CONTACT-MR. DANIEL OWENS, PROJECT COORDINATOR, CITY OF ROSWELL RECREATION & PARKS DEPT. (678) 794-5109

DRIVE-THRU WITH METAL ROOF SEE SHEETS 2 & 3

CANOPY WALK WITH METAL ROOF. SEE SHEETS 2 & 3.

**SITE SURVEY- EXTERIOR  
PHYSICAL ACTIVITY BUILDING "B"**

1"=10'

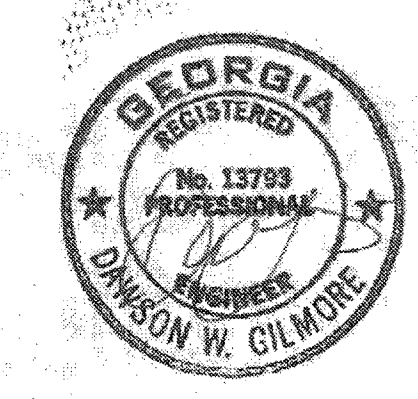

 <b>DMD ENGINEERING AND TESTING, INC</b>		
EXTERIOR RENOVATIONS-PHICAL ACTIVITY CENTER ROSWELL AREA PARK FOR CITY OF ROSWELL RECREATION & PARKS DEPT., GEORGIA		
<small>10495 WOODSTOCK ROAD ROSWELL, GA 30075</small> <span style="float: right;"><small>NORTH FULTON COUNTY, C</small></span>		
DATE: 04/08/2016	DESIGN BY: D. W. GILMORE, P.E.	
SCALE: AS NOTED	DRAWN BY: D. W. GILMORE	SHEET: 1 OF 3



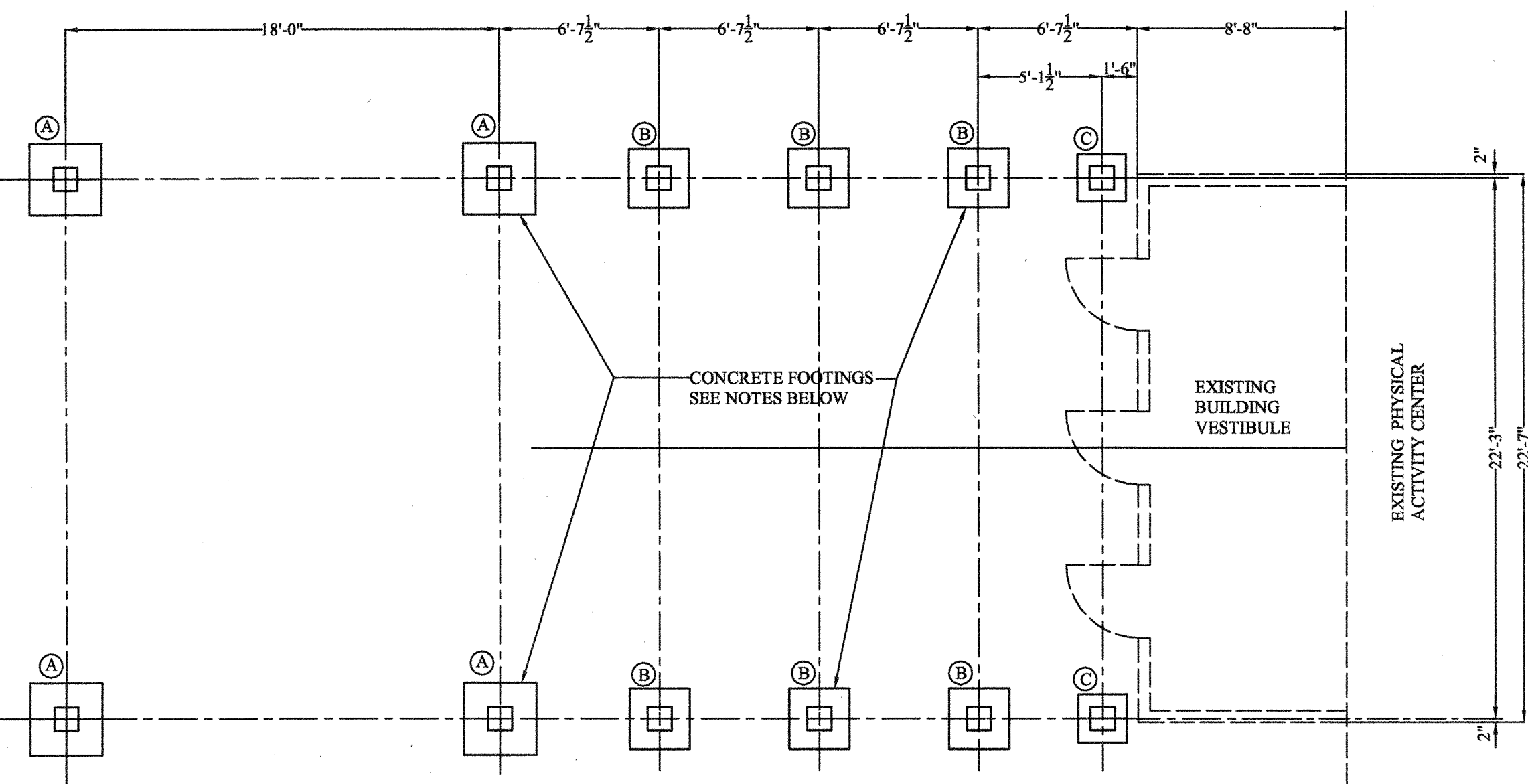
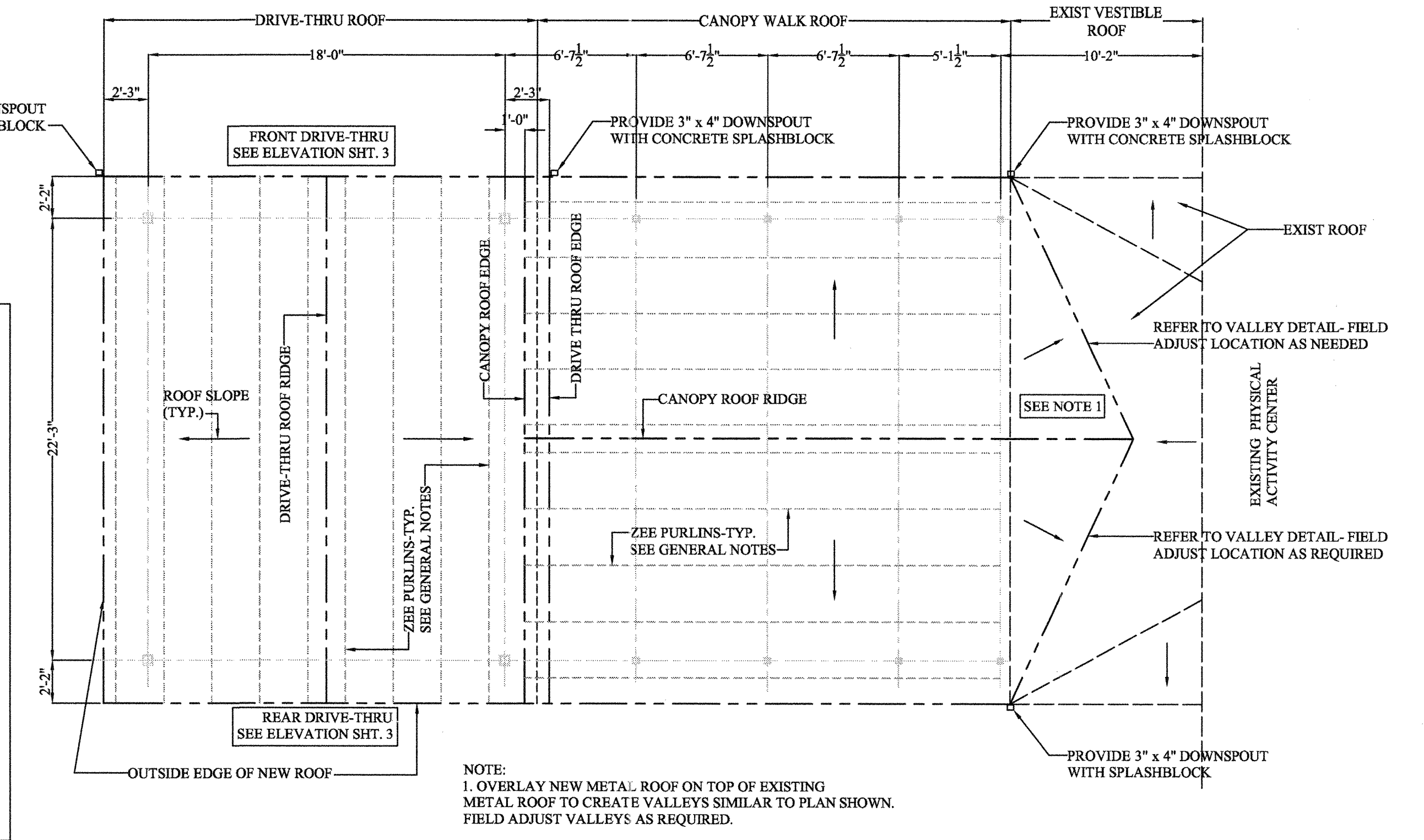
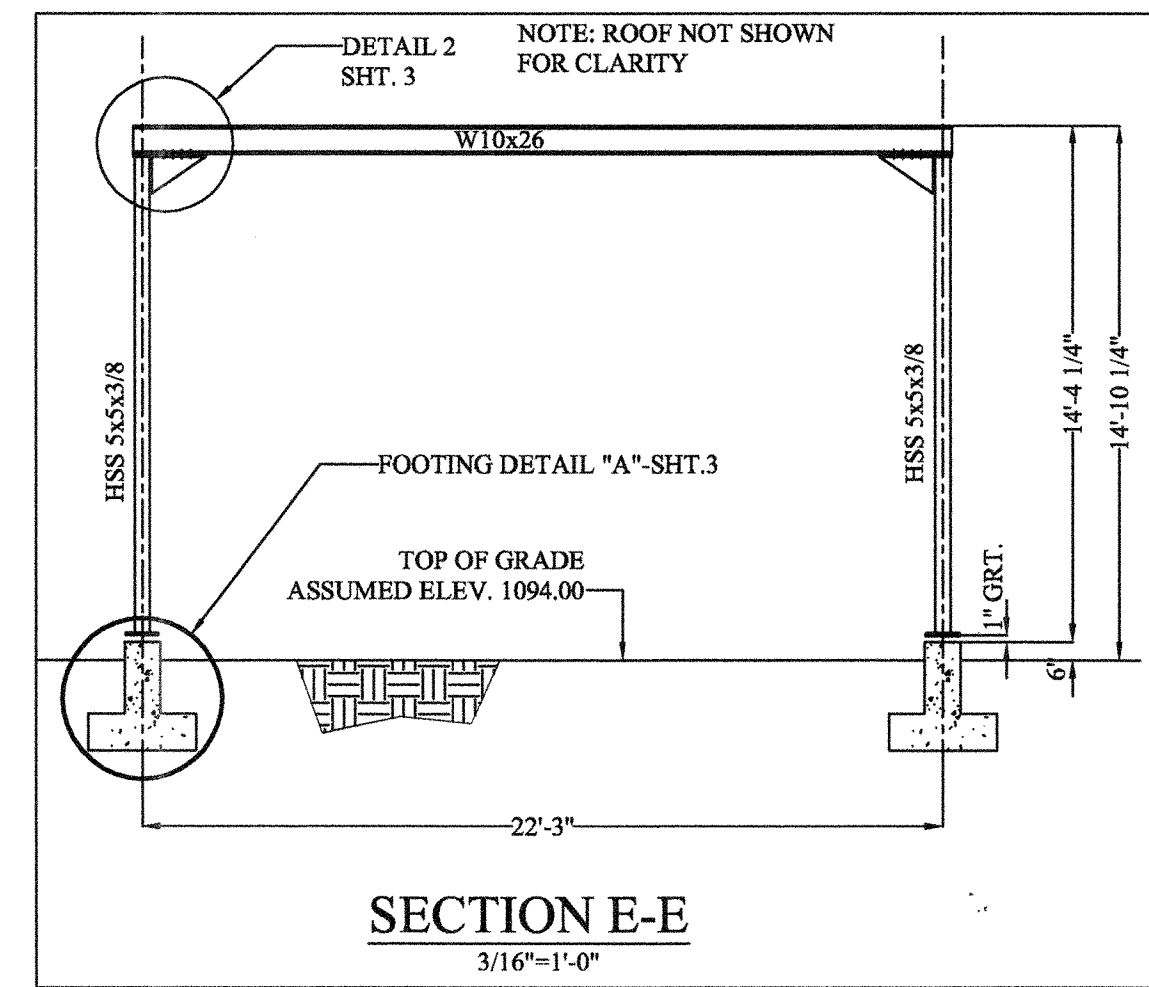
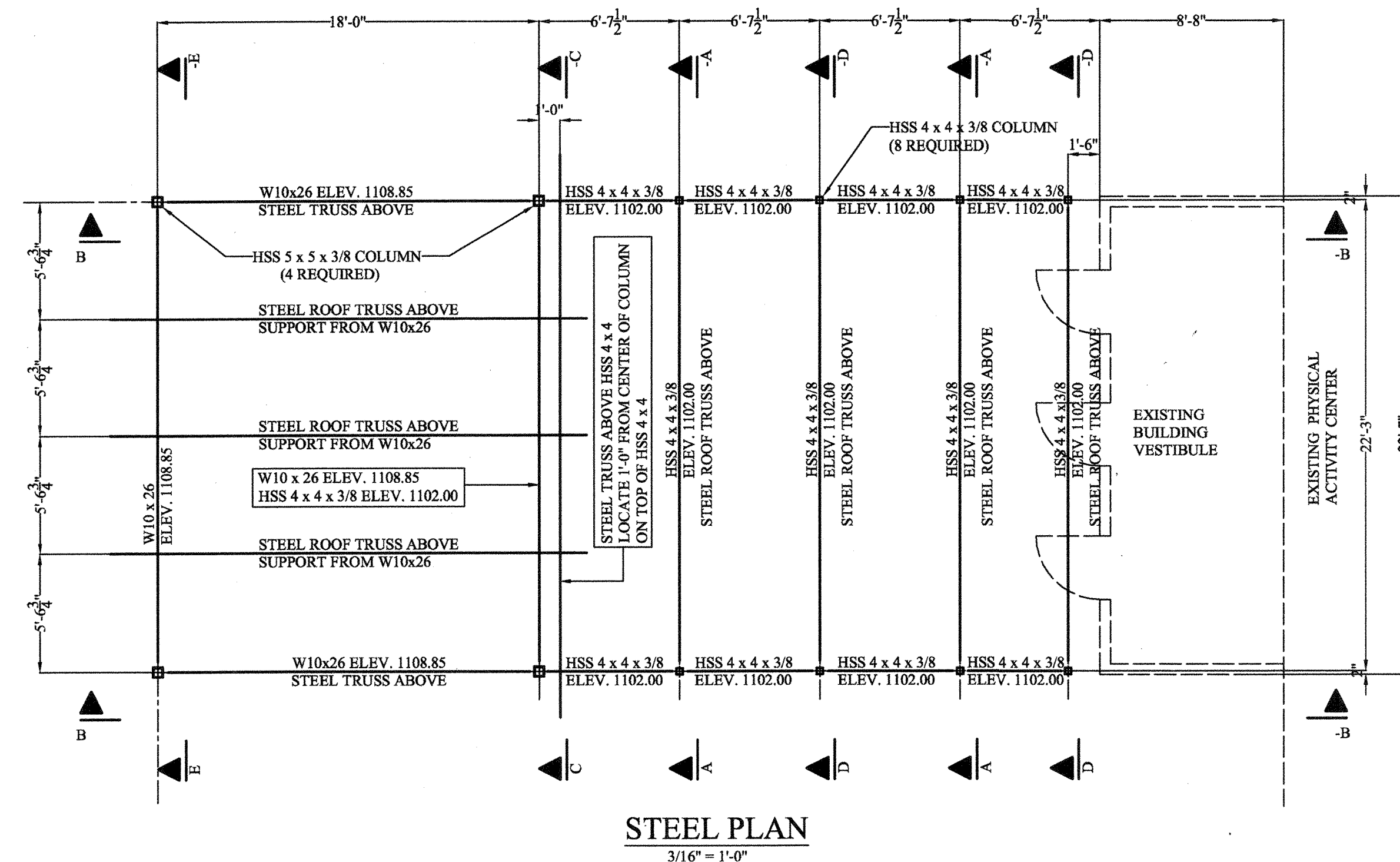

NOTE:  
 (A) - FOOTING DETAIL "A"  
 (B) - FOOTING DETAIL "B"  
 (C) - FOOTING DETAIL "C"

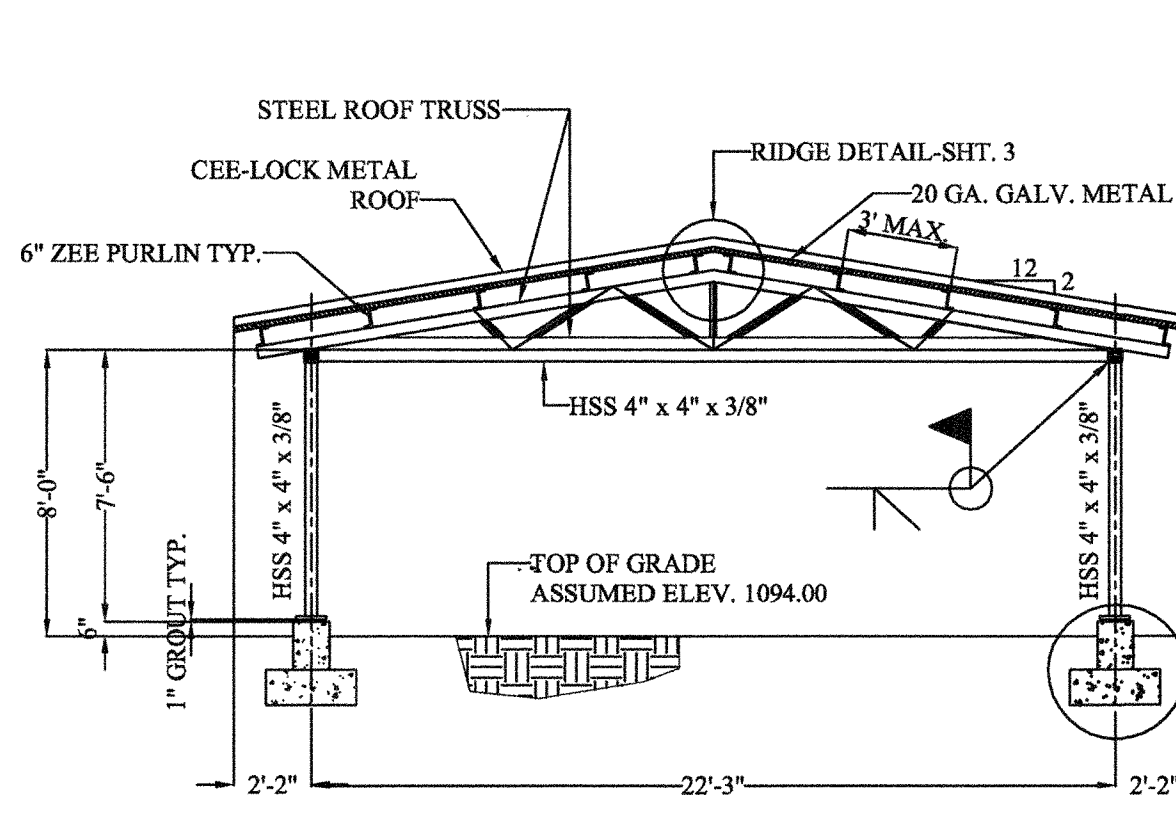
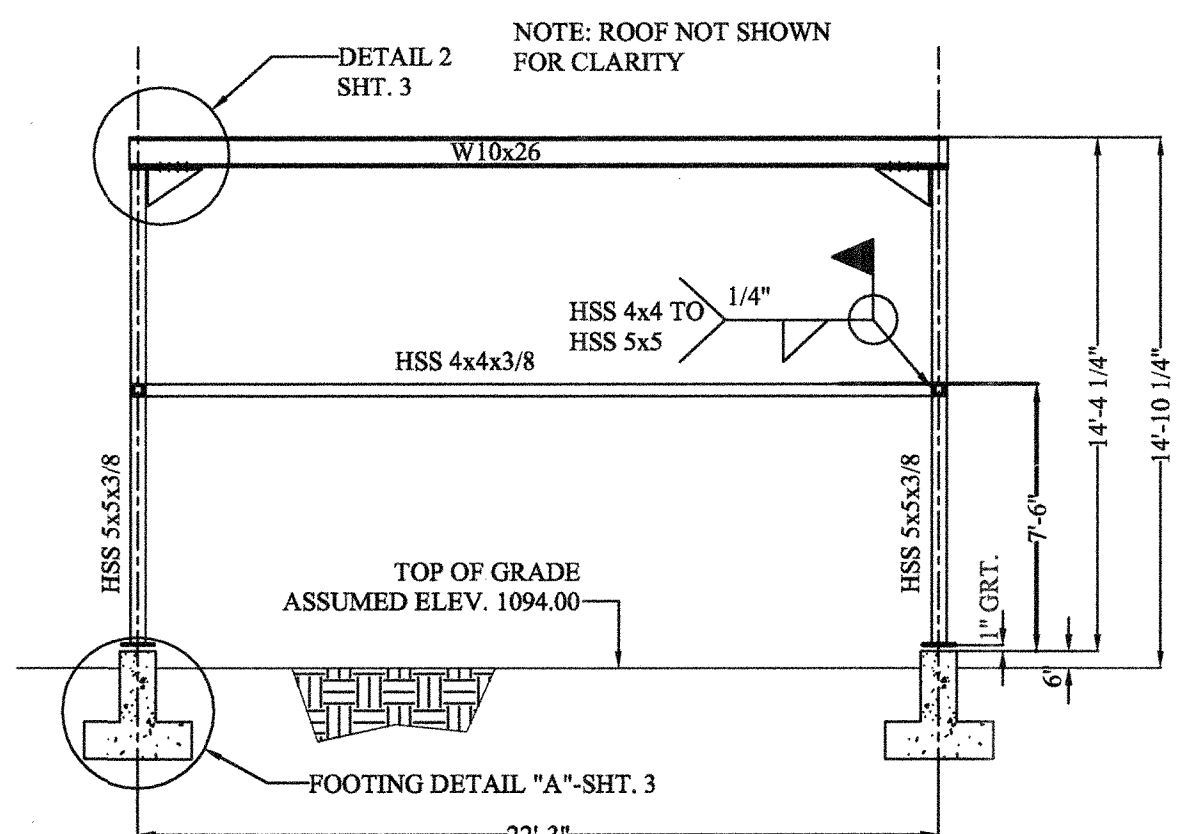
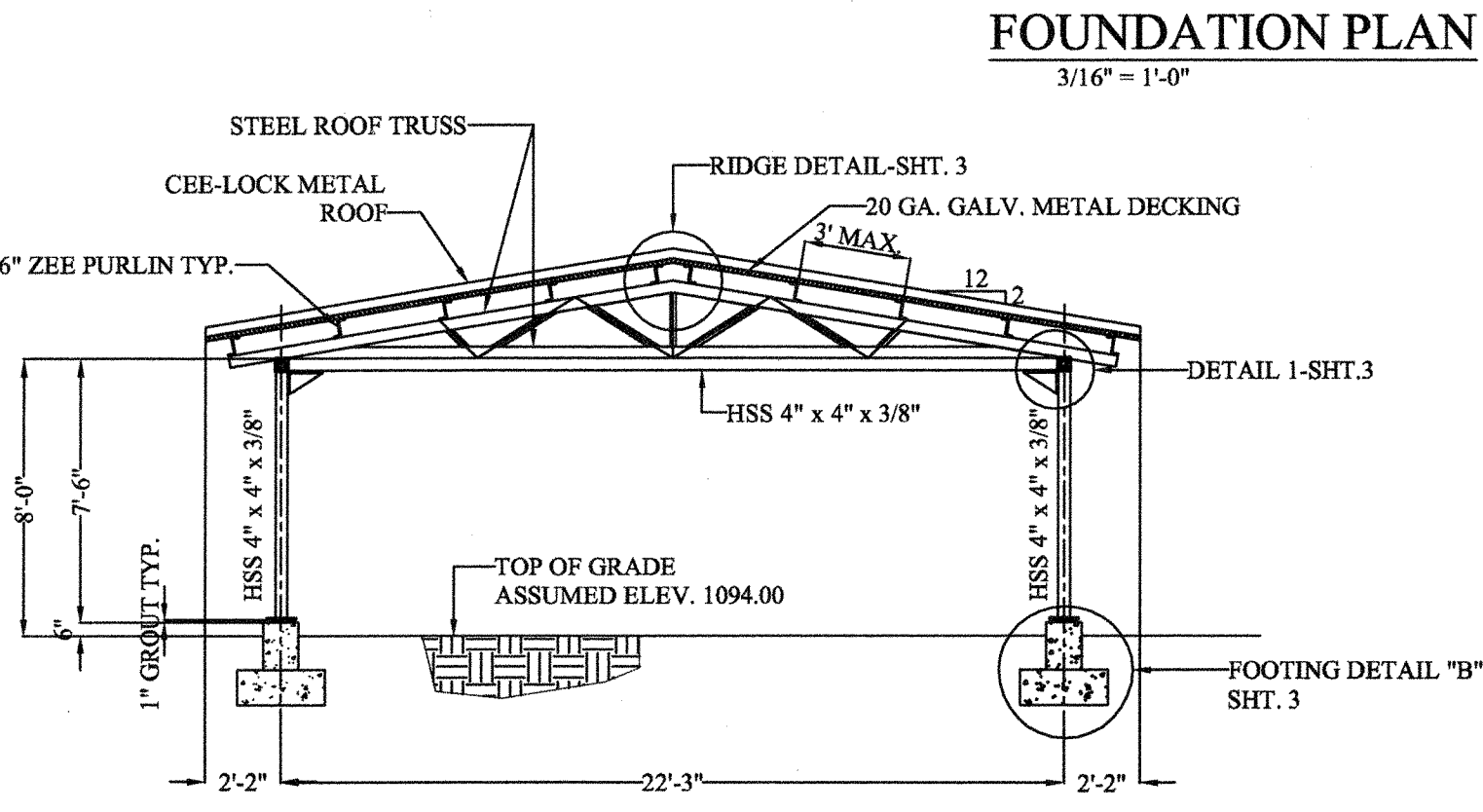
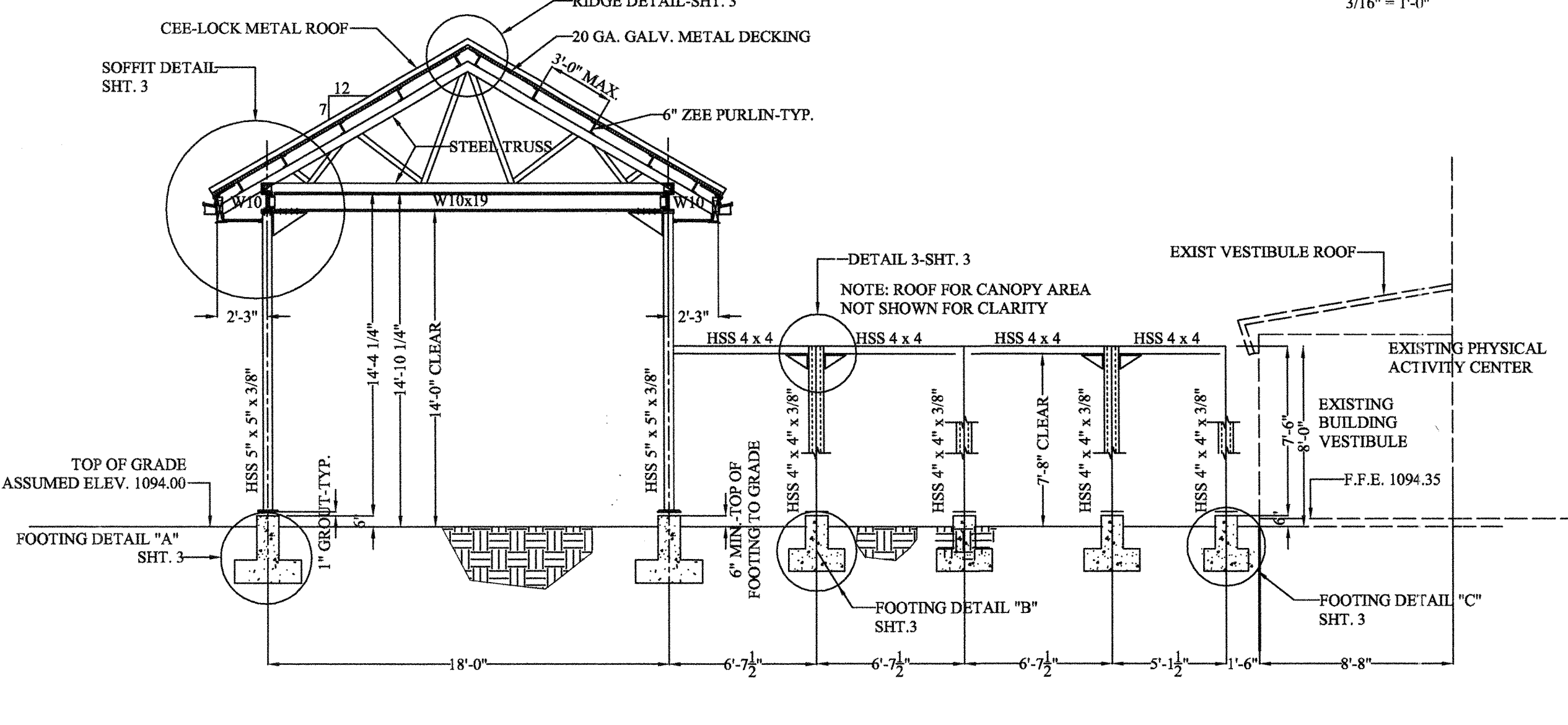

NOTES:  
 1. FOR GENERAL NOTES AND ADDITIONAL DETAILS SEE SHEET 3 OF 3.  
 2. FOR GENERAL LOCATION OF THE DRIVE-THRU AND CANOPY WALK STRUCTURES SEE SHEET 1 OF 3.  
 3. FOR COLUMN BASE PLATES REFER TO "BASE PLATE DETAILS" ON SHT. 3. USE "BASE PLATE 1" FOR ALL HSS 5 x 5 x 3/8 COLUMNS (4 TOTAL REQ'D). USE "BASE PLATE 2" FOR ALL HSS 4 x 4 x 3/8 COLUMNS (8 TOTAL REQ'D). FOR ANCHOR BOLTS REFER TO ANCHOR BOLT DETAIL ON SHT. 3.

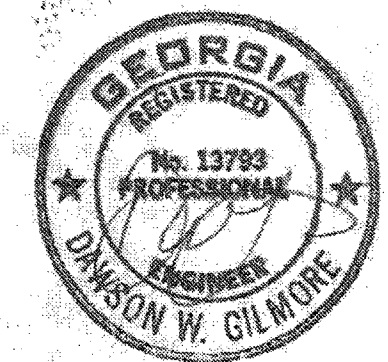

**DMD ENGINEERING AND TESTING, INC**  
 EXTERIOR RENOVATIONS-PLANS & SECTIONS  
 PHYSICAL ACTIVITY CENTER  
 ROSWELL PARK AREA  
 FOR  
 CITY OF ROSWELL RECREATION & PARKS DEPT.  
 10495 WOODSTOCK ROAD  
 ROSWELL, GA, 30075  
 NORTH FULTON COUNTY, GA

DATE: 04/08/2016  
 DESIGN BY: D. W. GILMORE, P.E.  
 SCALE: AS NOTED  
 DRAWN BY: D. W. GILMORE  
 SHEET: 2 OF 3

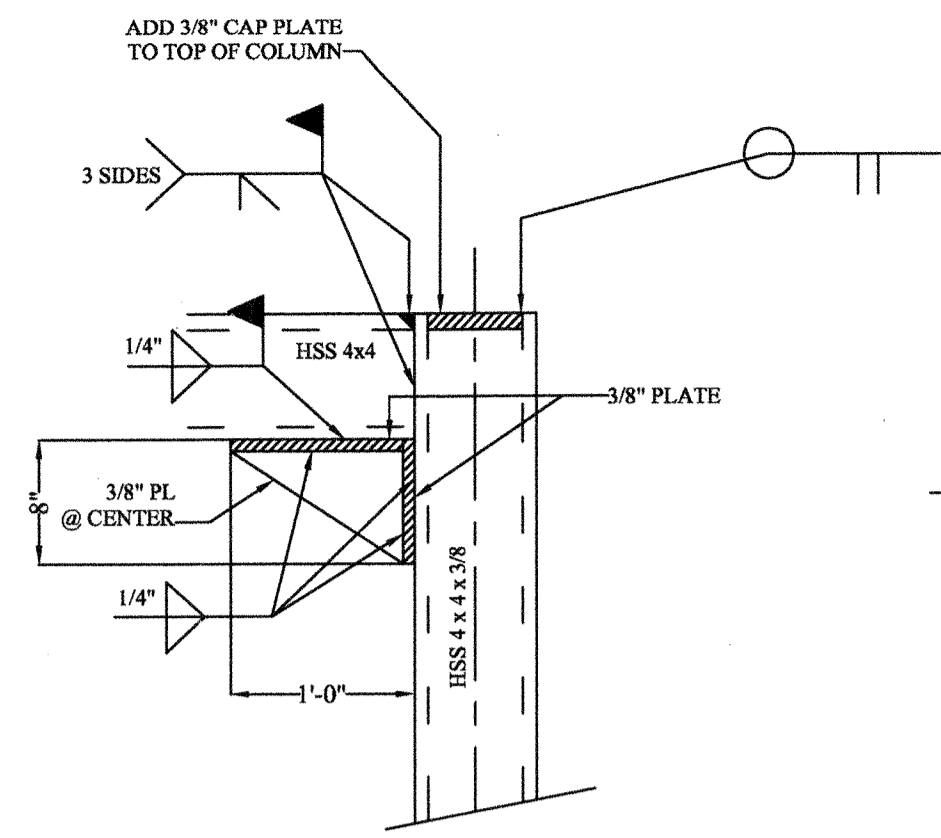

**DETAIL 1**  
NTS

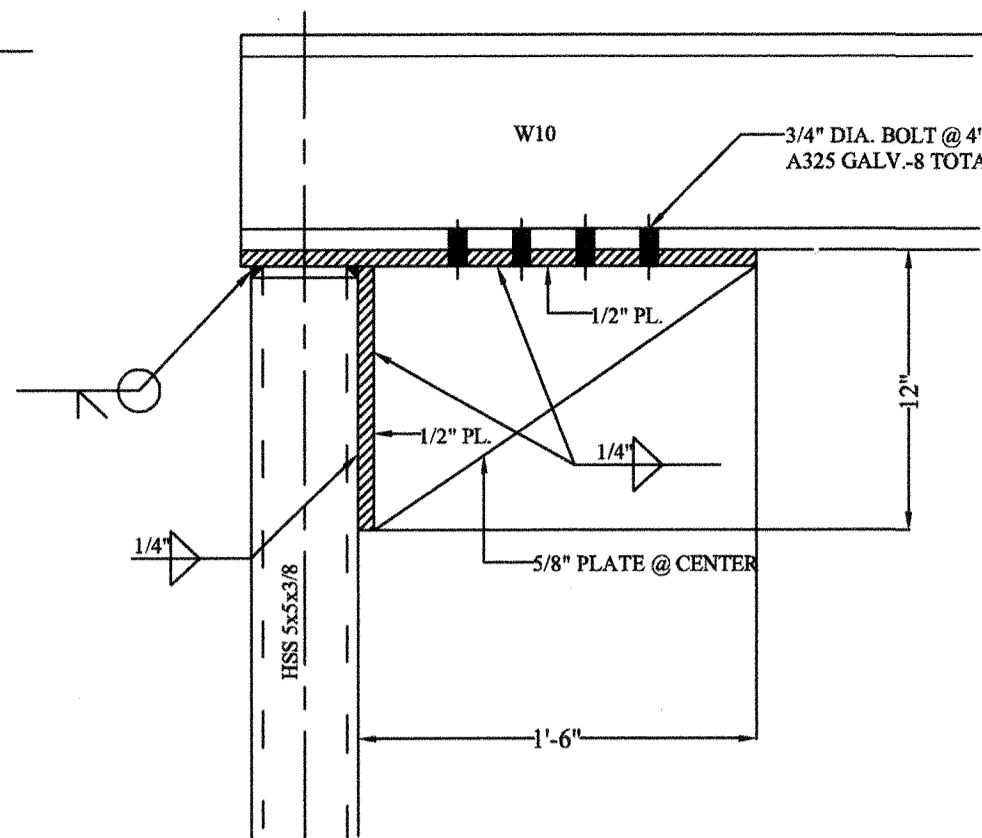

**DETAIL 2**  
NTS

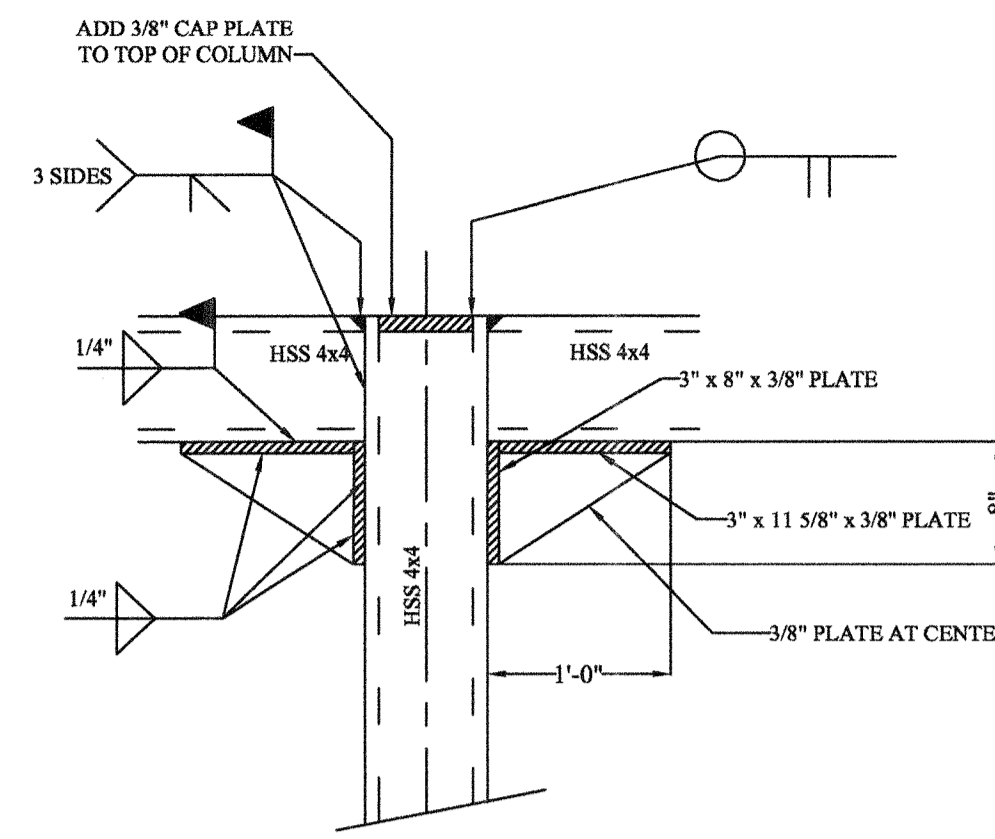

**DETAIL 3**  
NTS

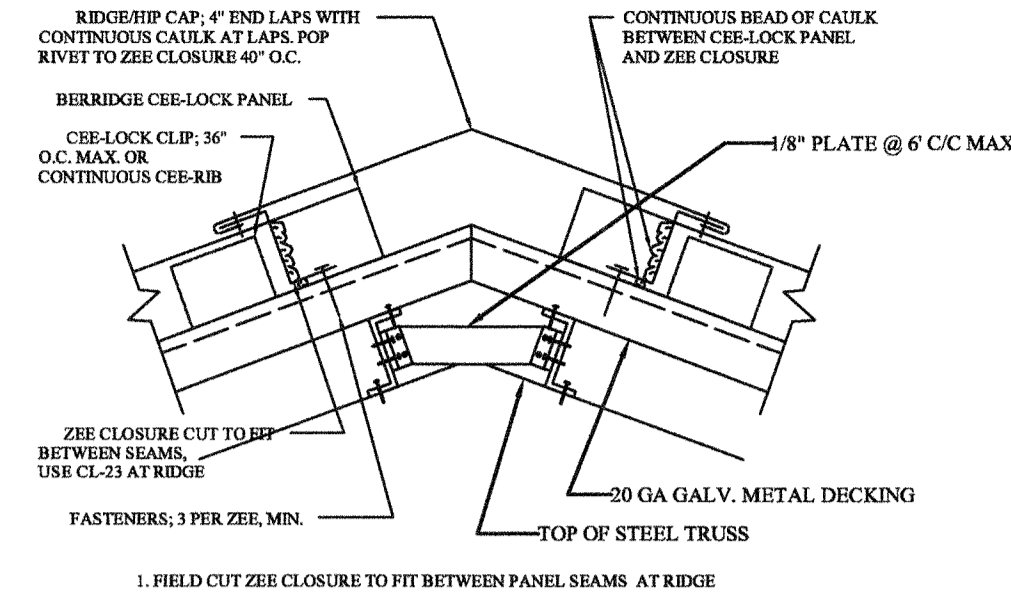

**RIDGE DETAIL**  
NTS

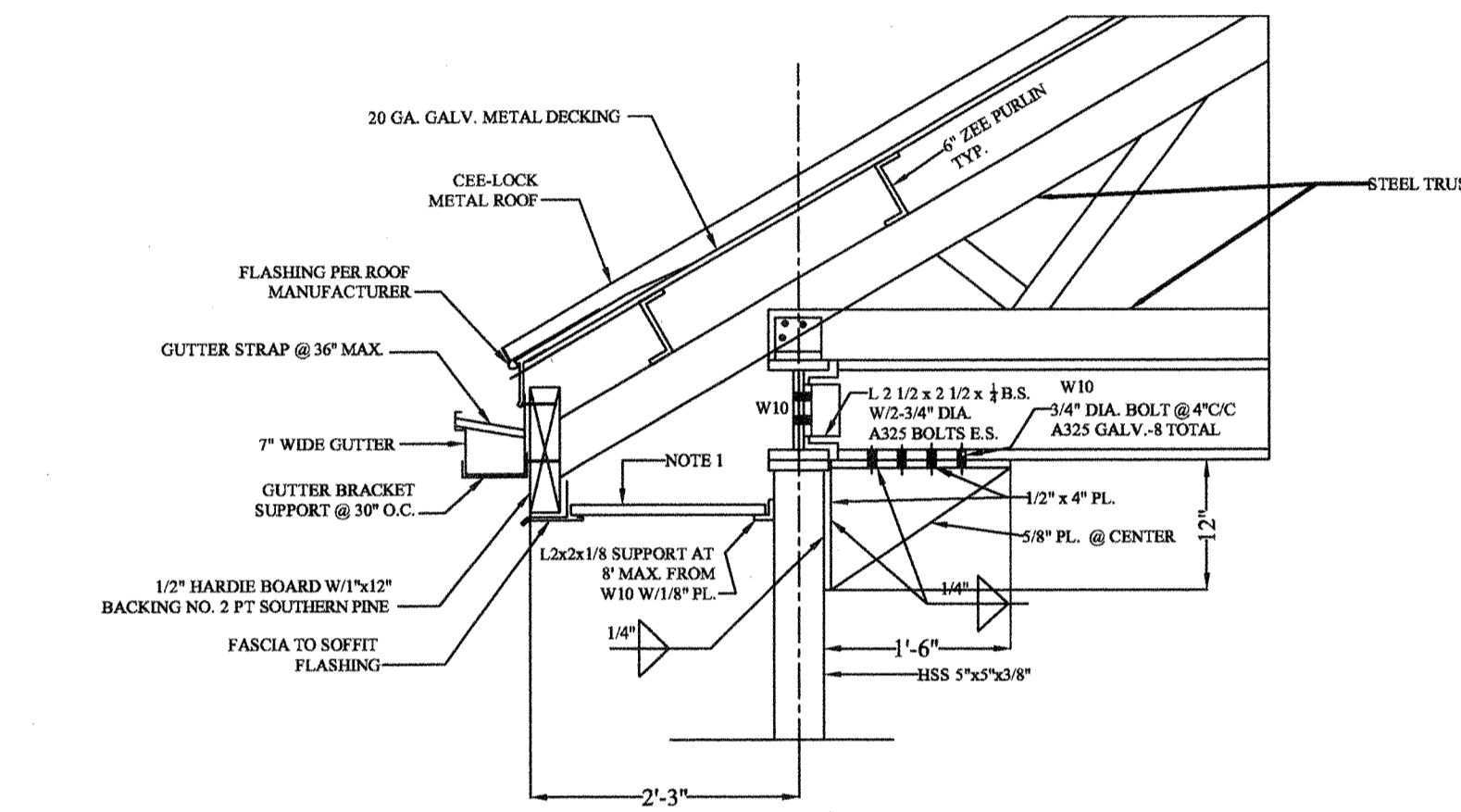

**SOFFIT DETAIL**  
NTS

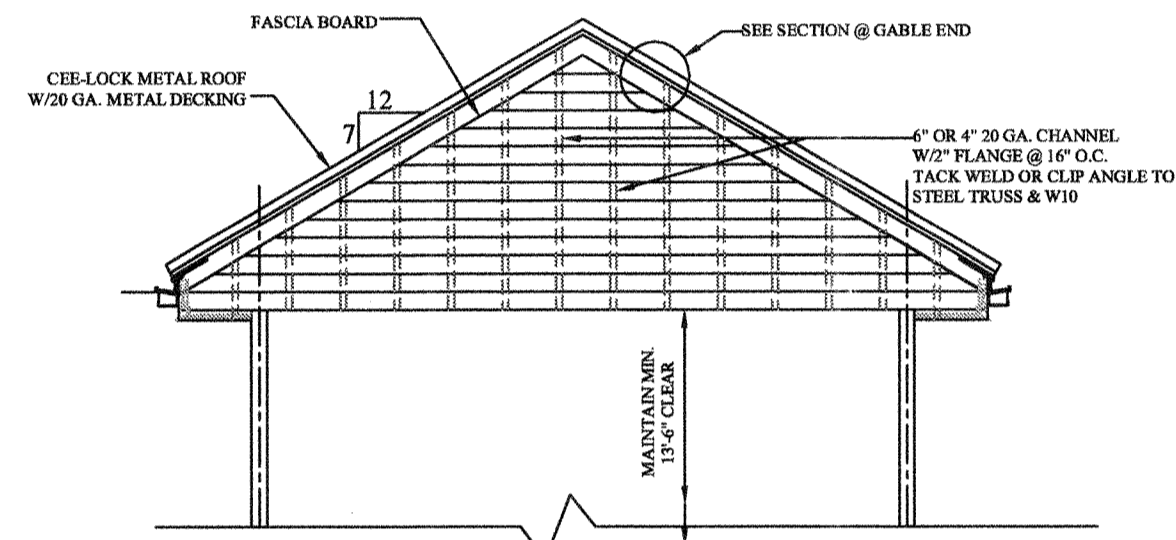

**COVERED DRIVE-THRU FRONT/REAR ELEVATION**  
3/16\"/>

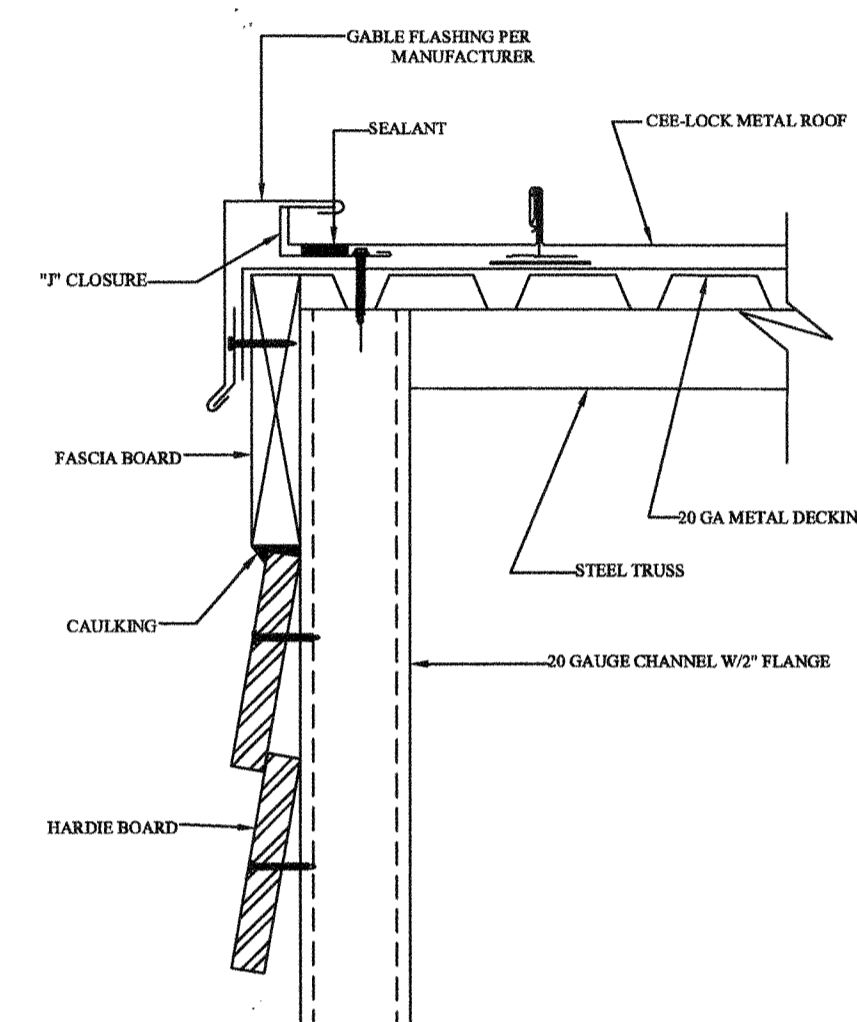

**SECTION @ GABLE END**  
NTS

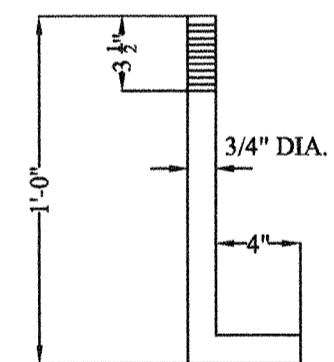

**ANCHOR BOLT DETAIL**  
NTS

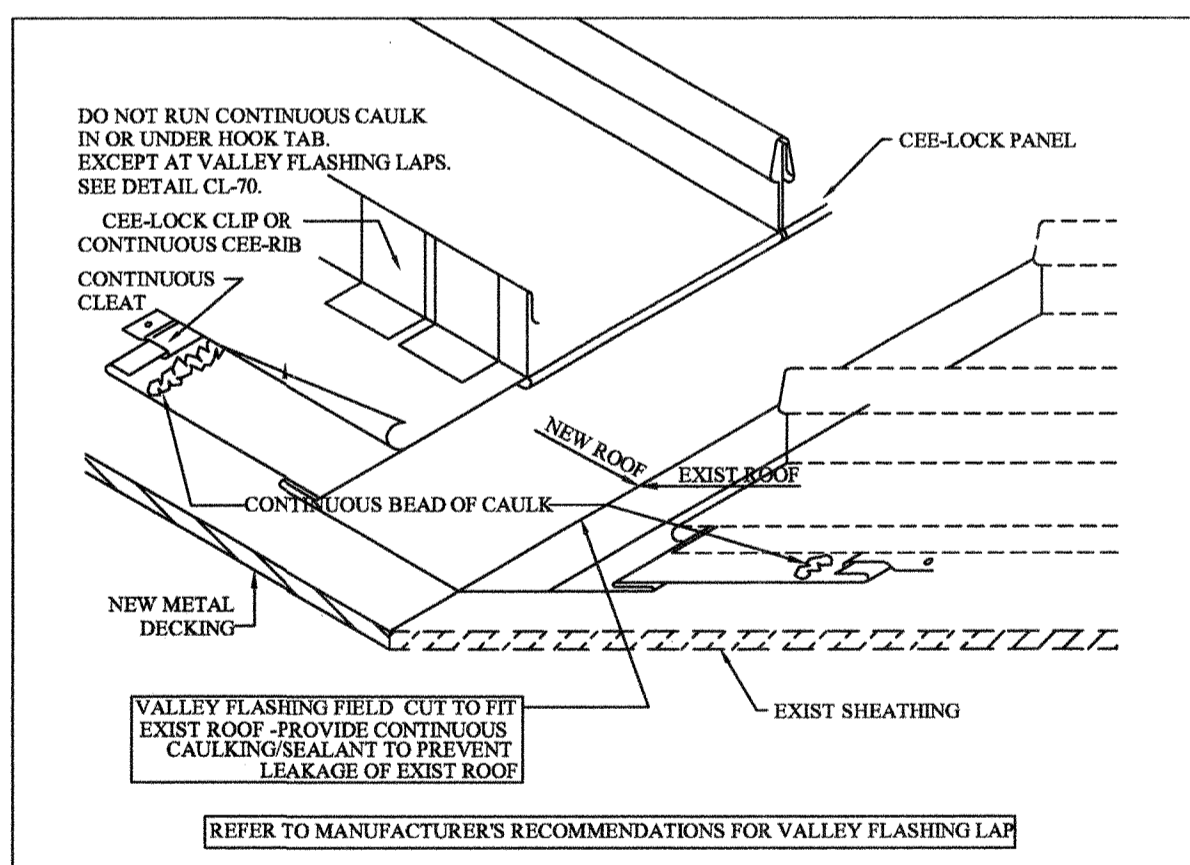

**VALLEY DETAIL**  
NTS

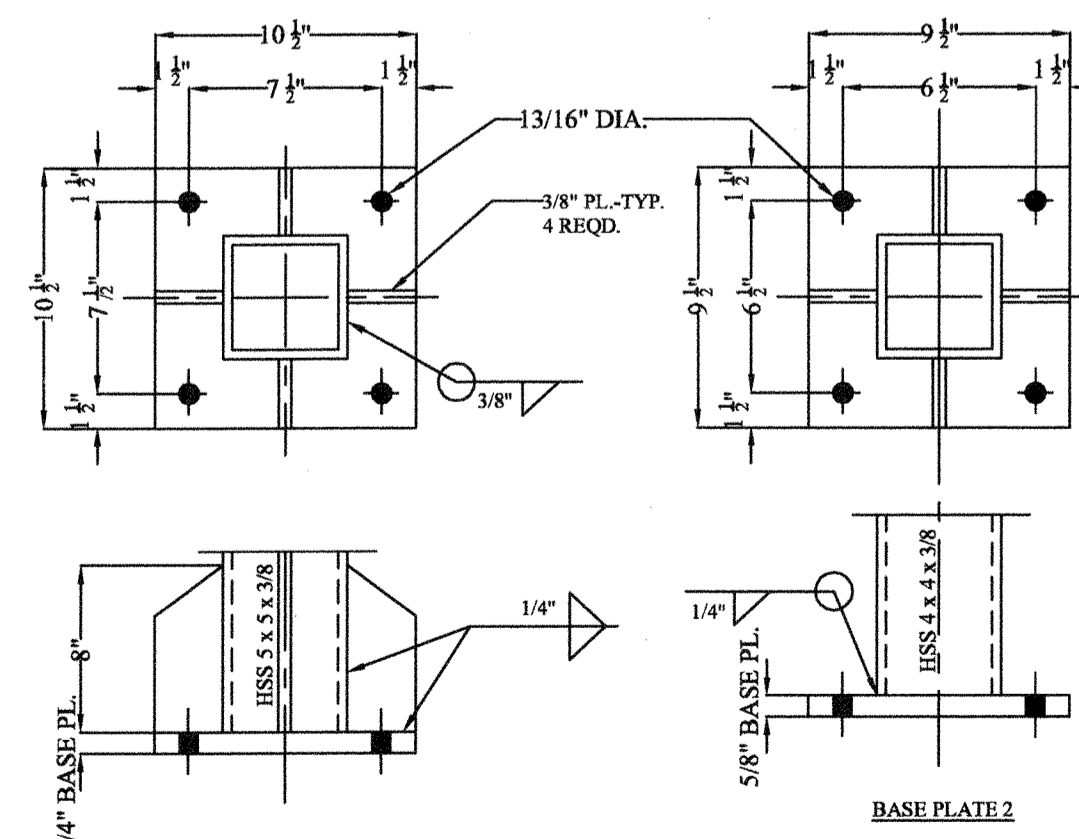

**BASE PLATE DETAILS**  
NTS

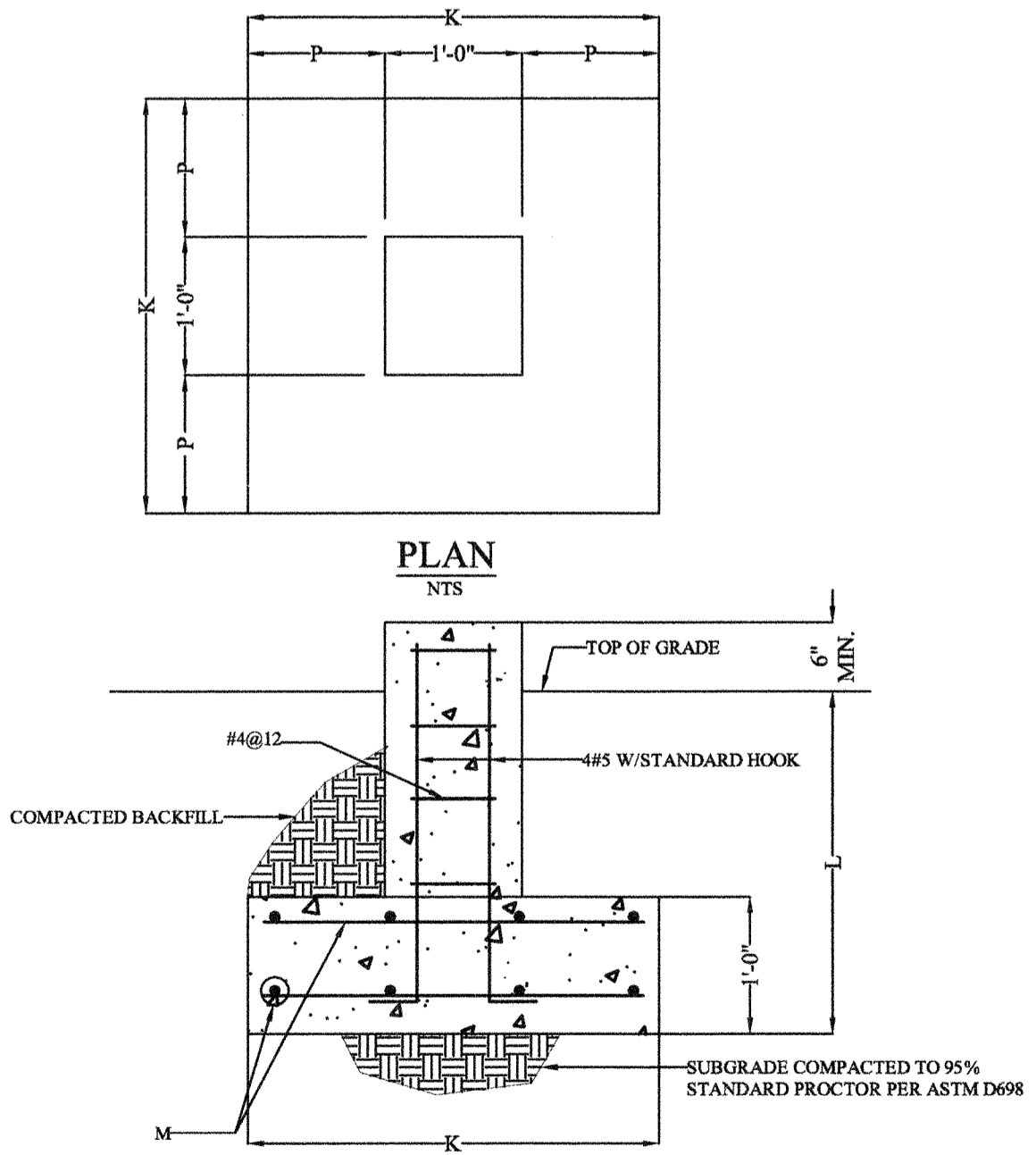

FOOTING	K	L (MIN.)	M	P
A	3'-3"	3'-0"	485 B.W.	1'-1 1/2"
B	2'-4"	2'-0"	485 B.W.	9"
C	2'-0"	2'-0"	345 B.W.	6"

**FOOTING DETAIL "A", "B", "C"**  
NTS

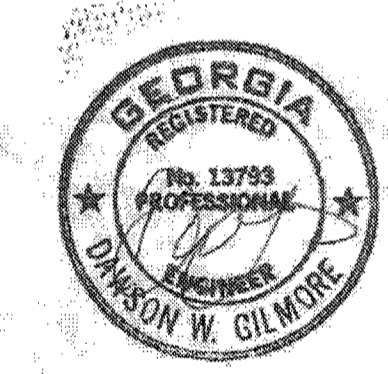

**GENERAL NOTES**

- THE ESCAPE OF SEDIMENT FROM THE SITE SHALL BE PREVENTED BY THE INSTALLATION OF EROSION AND SEDIMENT CONTROL MEASURES AND PRACTICES PRIOR TO, OR CONCURRENT WITH LAND DISTURBING ACTIVITIES. DISTURBED AREAS SHALL BE STABILIZED WITH PERMANENT VEGETATION.
- CONCRETE SHALL DEVELOP A 28 DAY COMPRESSIVE STRENGTH OF 3000 PSI. PORTLAND CEMENT SHALL BE IN ACCORDANCE WITH ASTM C150/150M, TYPE I OR II. MATERIALS, MIXING AND PLACEMENT OF CONCRETE AND REINFORCING STEEL SHALL BE IN ACCORDANCE WITH ACI 301 AND ACI 318. ALL REINFORCING STEEL SHALL BE NEW HILLET STEEL CONFORMING TO ASTM A615 GRADE 60. CONCRETE CYLINDERS FOR STRENGTH TESTING MAY BE REQUIRED AT THE OWNER'S DISCRETION. CEMENTITIOUS NON-SHRINK GROUT FOR COLUMN BASE PLATES SHALL MEET THE REQUIREMENTS OF ASTM-C-1107, NONMETALLIC, MINIMUM COMPRESSIVE STRENGTH OF 4500 PSI, "DURAGROUT" BY L & M CONSTRUCTION CHEMICALS, INC. OR APPROVED EQUAL.
- STEEL ROOF DECKING SHALL BE UNITED STEEL DECK TYPE B AS MANUFACTURED BY CMC JOIST & DECK OR APPROVED EQUAL. DECK SHALL BE MADE FROM STEEL CONFORMING TO ASTM A653 GRADE 50. DECKING SHALL BE GALVANIZED CONFORMING TO THE REQUIREMENTS OF ASTM A653 COATING CLASS 660 OR G90. A SHOP COAT OF PRIMER SHALL BE APPLIED OVER CLEANED AND PHOSPHATIZED GALVANIZED STEEL. COLOR OF FINISHED COAT SHALL BE AS SPECIFIED BY THE OWNER. DECKING SHALL BE ATTACHED TO THE PURLINS IN ACCORDANCE WITH THE MANUFACTURER'S RECOMMENDATIONS. DECKING STRONG AXIS SHALL RUN PERPENDICULAR TO THE PURLINS.
- PREFORMED METAL ROOF SHALL BE BY BERRIDGE MANUFACTURING CO., SAN ANTONIO, TEXAS OR SUBSTITUTIONS THAT FULLY COMPLY WITH SPECIFIED REQUIREMENTS. ROOF PANELS SHALL BE BERRIDGE CEE-LOCK STANDING SEAM PANELS. STANDING SEAM TO BE OF AN INTERLOCKING, SNAP-ON DESIGN. PANELS SHALL BE SITE-FORMED WITH THE BERRIDGE MODEL CL-21 PORTABLE ROLL-FORMER IN CONTINUOUS LENGTHS FROM RIDGE TO EAVE OR FACTORY-FORMED TO A MAXIMUM OF 40'. ALL ACCESSORY MATERIALS REQUIRED FOR CONSTRUCTION (FASTENERS, SEALANT, ETC.) SHALL COMPLY WITH THE MANUFACTURER'S RECOMMENDATIONS. PRE-FINISHED METAL SHALL BE ALUMINUM-ZINC ALLOY COATED (AZ-50 GALVALUME) STEEL SHEET, 24 GAUGE, ASTM 792-08, GRADE 40, YIELD STRENGTH 40 KSI MINIMUM. FINISH SHALL BE FULL STRENGTH DYNAR 500 OR HYLAR 900 FLUOROPOLYMER COATING APPLIED BY THE MANUFACTURER. COLOR SHALL BE AS SPECIFIED BY THE OWNER. FINISH SHALL HAVE A 20 YEAR WARRANTY AGAINST CRACKING, PEELING AND FADING. ROOFING SHALL FURNISH GUARANTEE COVERING WATER TIGHTNESS OF THE ROOFING SYSTEM FOR A PERIOD OF 2 YEARS FROM THE DATE OF SUBSTANTIAL COMPLETION. INSTALLATION SHALL COMPLY WITH MANUFACTURER'S STANDARD INSTRUCTIONS AND CONFORM TO STANDARDS SET FORTH IN THE ARCHITECTURAL SHEET METAL MANUAL PUBLISHED BY SMACNA, IN ORDER TO ACHIEVE A WATERTIGHT INSTALLATION.
- STRUCTURAL STEEL SHALL BE IN ACCORDANCE WITH ASTM A36. CONSTRUCTION AND ERECTION SHALL BE IN ACCORDANCE WITH THE AMERICAN INSTITUTE OF STEEL CONSTRUCTION STANDARDS. ALL BOLTED CONNECTIONS SHALL USE HIGH STRENGTH BOLTS CONFORMING TO ASTM A307. HOLLOW STRUCTURAL SECTIONS (HSS) SHALL CONFORM TO ASTM A500 GRADE "C". ALL STRUCTURAL STEEL, INCLUDING HSS SHALL BE GALVANIZED CONFORMING TO THE REQUIREMENTS OF ASTM A653 COATING CLASS G60 OR G90. A SHOP COAT OF PRIMER SHALL BE APPLIED OVER CLEANED AND PHOSPHATIZED GALVANIZED STEEL. FINISH COAT COLOR SHALL BE AS SPECIFIED BY THE OWNER. ALL WELDERS SHALL BE CERTIFIED THE AMERICAN WELDING SOCIETY (AWS). ALL GROOVE WELDS SHALL BE COMPLETE PENETRATION. STEEL WELDING ELECTRODES SHALL CONFORM TO THE REQUIREMENTS OF AWS SPECIFICATION AWS A5.1, "SPECIFICATION FOR MILD STEEL COVERED ARC-WELDING ELECTRODES", EXCEPT THAT THEY SHALL BE UNIFORMLY AND HEAVILY COATED (NOT WASHED) AND SHALL BE OF SUCH A NATURE THAT THE COATING DOES NOT CHIP OR PEEL WHILE BEING USED WITH THE MAXIMUM AMPERAGE SPECIFIED BY THE MANUFACTURER.
- PRE-ENGINEERED COLD-FORMED STEEL TRUSSES ACCEPTABLE TRUSS MANUFACTURERS ARE TRUSSTEEL DIVISION OF ALPINE ENGINEERING PRODUCTS, INC., ALGIS METAL FRAMING LLC OR APPROVED EQUAL. TRUSS DESIGN SHALL BE BY THE TRUSS MANUFACTURER BASED ON THE FOLLOWING LOADING CONDITIONS:
  - WIND LOADS BASED ON ATLANTA, GA WIND ZONE (90 MPH).
  - ROOF LIVE LOAD - 30 PSF
  - DEAD LOADS - 10 PSF FOR CALCULATING UPLIFT CONDITIONS, 15 PSF FOR MAX. DOWNWARD LOADS.
 PROVIDE A COMPLETE HORIZONTAL FRAMING SYSTEM FOR LOCATIONS INDICATED ON DRAWINGS, READY FOR DECK AND PURLIN INSTALLATION MEETING THE SPECIFIED REQUIREMENTS OF THE DRAWINGS. CHORDS: COLD-FORMED FROM ASTM A553/653M GALVANIZED STEEL SHEET, MINIMUM G60 COATING, MINIMUM YIELD STRENGTH OF 55,000 PSI. WEBS: COLD-FORMED ASTM A500 STEEL STRUCTURAL TUBING, MINIMUM YIELD STRENGTH OF 45,000 PSI. DIMENSIONS AND GAUGES AS REQUIRED FOR LOAD CONDITIONS. FASTENERS, SCREW OR OTHERWISE, AS RECOMMENDED BY THE MANUFACTURER. TRUSS DESIGNER SHALL BE A PROFESSIONAL ENGINEER REGISTERED IN THE STATE OF GEORGIA. SHOP DRAWINGS SHALL BE PREPARED INDICATING DETAILS OF TRUSS LOADING, REACTIONS, UPLIFTS, SUPPORT LOCATIONS, MATERIAL SIZES AND GAUGES, PERMANENT TRUSS WEB BRACING, AND SPLICES AS REQUIRED FOR A COMPLETE INSTALLATION. PROVIDE DESIGN OF TRUSSES USING DESIGN METHODOLOGIES RECOMMENDED IN AISI AND LORSA REFERENCES. INSTALL TRUSSES IN ACCORDANCE WITH TRUSS MANUFACTURER'S INSTRUCTIONS AND TRUSS FABRICATOR'S SHOP DRAWINGS. PROVIDE BRACING THAT HOLDS TRUSSES STRAIGHT AND PLUMB AND IN SAFE CONDITION UNTIL DECKING AND PERMANENT TRUSS BRACING HAS FASTENED TO FORM A STRUCTURALLY SOUND FRAMING SYSTEM. INSTALL ALL ERECTION BRACING AND PERMANENT BRACING AND BRIDGING BEFORE APPLICATION OF ANY LOADS. FOLLOW RECOMMENDATIONS OF LORSA FIELD INSTALLATION GUIDE FOR COLD-FORMED STEEL ROOF TRUSSES.
- PURLINS SHALL BE 16 GAUGE Z PURLINS, BY FLEXOSPAN, INC. OR APPROVED EQUAL. USE 6" Z WITH A 2 1/2" FLANGE. ATTACH WITH CLIP ANGLE & 2-#10 SS SDS SCREWS AT EACH TRUSS OR AS REQUIRED BY THE MANUFACTURER.
- GABLE ENDS OF DRIVE-THRU COVERED ROOF SHALL BE COVERED BY HARDEPLANK HZS LAP SIDING AS MANUFACTURED BY JAMES HARDIE BUILDING PRODUCTS, INC OR APPROVED EQUAL. TYPE SHALL BE 8 1/4" WITH 7" EXPOSED, BEADED OR SMOOTH AS REQUESTED BY THE OWNER. FASCIA AND TRIM AND LAP SIDING SHALL BE IN CONFORMANCE WITH ASTM C1186 TYPE A, GRADE II ATTACH SIDING TO METAL STUDS AND INSTALL MATERIALS IN ACCORDANCE WITH THE MANUFACTURER'S INSTALLATION INSTRUCTIONS.
- BEARING CAPACITY OF SOIL FOR CONCRETE FOOTINGS SHALL BE A MINIMUM OF 2000 PSF. A LICENSED GEOTECHNICAL ENGINEER IN THE STATE OF GEORGIA SHALL VERIFY 2000 PSF BEARING PRESSURE IS AVAILABLE.
- CONTRACTOR SHALL VERIFY NO UNDERGROUND UTILITIES RUN UNDER THE STRUCTURE PRIOR TO EXCAVATING FOR FOOTINGS.
- CONTRACTOR SHALL VERIFY ALL DIMENSIONS PRIOR TO CONSTRUCTION. IF ANY DISCREPANCIES FROM THE DRAWINGS OCCUR CONTACT THE STRUCTURAL ENGINEER PRIOR TO CONSTRUCTION FOR THIS PROJECT.
- CONTRACTOR SHALL FOLLOW ALL OSHA GUIDELINES FOR SAFETY DURING CONSTRUCTION. ALL CONSTRUCTION SHALL BE IN ACCORDANCE WITH 2012 INTERNATIONAL BUILDING CODE WITH GEORGIA ADJUSTMENTS. ALL CONSTRUCTION SHALL BE PERFORMED BY A EXPERIENCED QUALIFIED LICENSED CONTRACTOR IN THE STATE OF GEORGIA.



**DMD ENGINEERING AND TESTING, INC**

**EXTERIOR RENOVATIONS-DETAILS, NOTES  
PHYSICAL ACTIVITY CENTER  
ROSWELL PARK AREA  
FOR  
CITY OF ROSWELL RECREATION & PARKS DEPT.**

10495 WOODSTOCK ROAD ROSWELL, GA 30075 NORTH FULTON COUNTY, GA

DATE: 04/08/2016 DESIGN BY: D. W. GILMORE, P.E.

SCALE: AS NOTED DRAWN BY: D. W. GILMORE SHEET: 3 OF 3